

Prosilica GC

2450



- Sony ICX625 CCD sensor
- 15 fps at full resolution
- Rugged housing
- Video-type auto iris

GigE Vision, Sony ICX625 CCD sensor, auto-iris, 15 fps

Prosilica GC2450 is a 5.0 Megapixel camera with a GigE Vision compliant Gigabit Ethernet port and Hirose I/O port. Prosilica GC2450 is offered in both monochrome and color models. This camera incorporates the high quality Type 2/3 (11.016 mm diagonal) Sony ICX625 CCD sensor with Super HAD CCD technology that provides superior image quality, excellent sensitivity, and low noise. At full resolution, this camera has a frame rate of 15 frames per second. With a smaller region of interest higher frame rates are possible. By default monochrome models ship with no optical filter and color models ship with a Type IRC30 IR cut filter.

Benefits and features

- Monochrome (GC2450) and color (GC2450C) models
- Screw mount RJ45 Ethernet connector for secure operation in industrial environments
- Supports cable lengths up to 100 meters (CAT-5e or CAT-6)
- Popular C-Mount lens mount
- Easy camera mounting via standard M3 threads or optional tripod adapter
- Easy software integration with Allied Vision's [Vimba SDK](#) and compatibility to the most popular [third party image-processing libraries](#).

Hardware options

- Various lens mounts: Select between C-Mount and CS-Mount
- Various optical filters: Select between B 270 ASG protection glass Type IRC30 IR pass filter.

See the [Modular Concept](#) for lens mount and optical filter options.

Specifications

Prosilica GC	2450
Interface	IEEE 802.3 1000baseT
Resolution	2448 (H) × 2050 (V)
Sensor	Sony ICX625
Sensor type	CCD Progressive
Shutter mode	Global shutter
Sensor size	Type 2/3
Pixel size	3.45 μm × 3.45 μm
Lens mount (default)	C-Mount
Max. frame rate at full resolution	15 fps
ADC	12 Bit
Image buffer (RAM)	64 MByte
Imaging performance	
Imaging performance data is based on the evaluation methods in the EMVA 1288 Release 3.1 standard for characterization of image sensors and cameras. Measurements are typical values for monochrome models measured at full resolution without optical filter. Contact Sales or AE for more information.	
Quantum efficiency at 529 nm	54 %
Temporal dark noise	10.7 e ⁻
Saturation capacity	3300 e ⁻
Dynamic range	49.3 dB
Absolute sensitivity threshold	11.2 e ⁻
Output	
Bit depth	8/12 Bit
Monochrome pixel formats	Mono8, Mono12, Mono12Packed
RGB color pixel formats	RGB8Packed, BGR8Packed
Raw pixel formats	BayerRG8, BayerRG12, BayerGR12Packed
General purpose inputs/outputs (GPIOs)	
TTL I/Os	1 input, 1 output
Opto-isolated I/Os	1 input, 1 output
RS232	1
Operating conditions/dimensions	
Operating temperature	0 °C to +40 °C ambient (without condensation)
Power requirements (DC)	5 to 25 VDC
Power consumption	3.8 W at 12 VDC
Mass	106 g
Body dimensions (L × W × H in mm)	59 × 46 × 33 (including connectors)

Prosilica GC

Regulations

2450

CE: 2014/30/EU (EMC), 2011/65/EU, including amendment 2015/863/EU (RoHS); FCC Class A; CAN ICES-003

Quantum efficiency

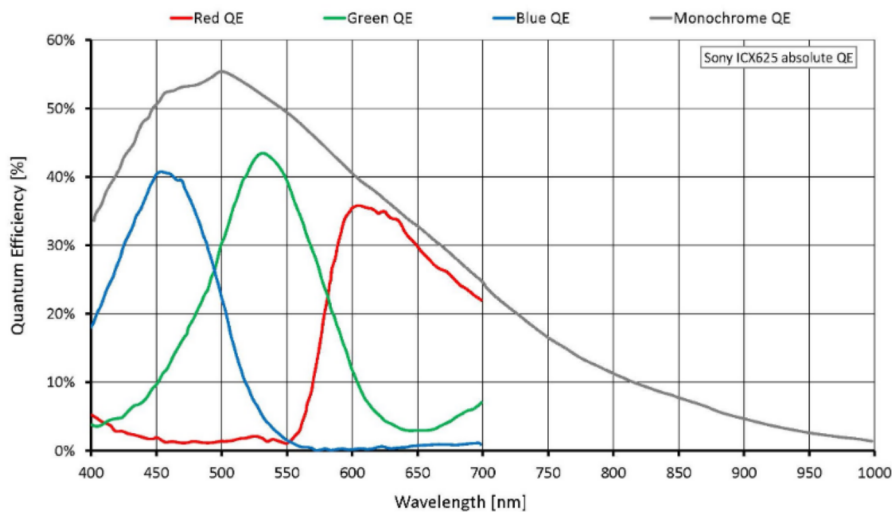

Features

Image optimization features:

- Auto gain (manual gain control: 0 to 24 dB, 1 dB increments)
- Auto exposure (manual exposure control: 10 μ s to 48.0 s; 1 μ s increments)
- Auto white balance (GC2450C only)
- Binning (horizontal and vertical) (sum)
- Black level (Offset)
- Gamma correction
- Hue, saturation, color transformation (GC2450C only)
- Three look-up tables
- Region of interest, DSP subregion (selectable region for auto features)

Camera control features:

- Auto-iris (video type)
- Event channel



- Global shutter (digital shutter)
- IEEE 1588 Precision Time Protocol
- Image chunk data
- Recorder and Multiframe acquisition modes
- RS232
- Three storable user sets
- StreamBytesPerSecond (bandwidth control)
- StreamHoldCapacity (Up to 12 frames at full resolution)
- Sync out modes: Trigger ready, input, exposing, readout, imaging, strobe, GPO
- Temperature monitoring (mainboard only)

Technical drawing

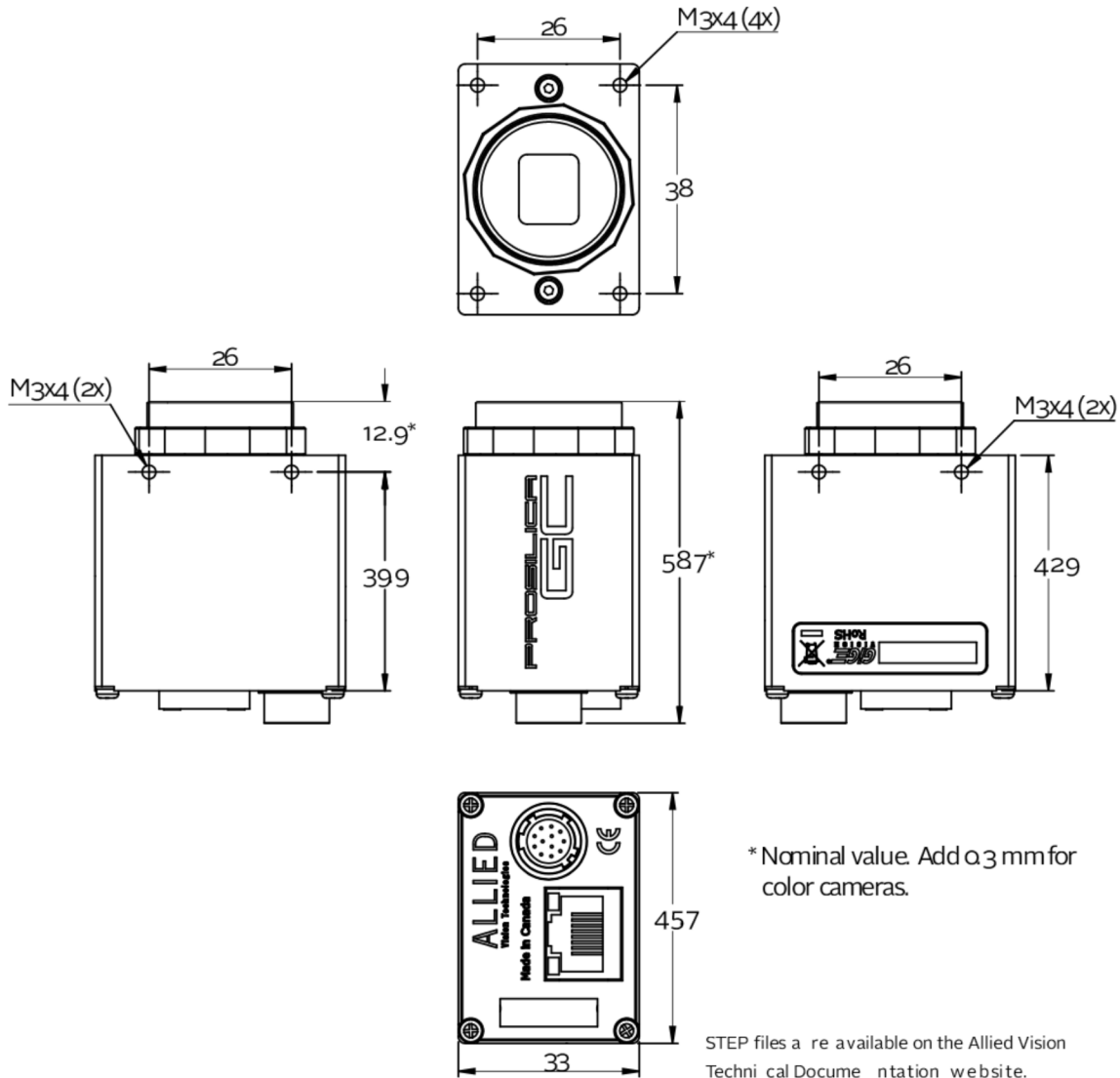



Applications

Prosilica GC2450 is ideal for a wide range of applications including:

- High-resolution industrial inspection
- LCD panel inspection
- Machine vision
- 3D metrology
- Public security
- Surveillance
- Traffic imaging/Intelligent Traffic Systems
- Embedded systems
- OEM applications