

Space-Division Multiplexed Transmission over 4200-km 3-Core Microstructured Fiber

R. Ryf¹, R.-J. Essiambre¹, A. H. Gnauck¹, S. Randel¹, M. A. Mestre¹, C. Schmidt¹, P. J. Winzer¹, R. Delbue², P. Pupalais², A. Sureka², T. Hayashi³, T. Taru³, and T. Sasaki³

¹Bell Laboratories, Alcatel-Lucent, 791 Holmdel-Keyport Rd, Holmdel, NJ, 07733, USA.

²LeCroy Corporation, 700 Chestnut Ridge Road, Chestnut Ridge, NY 10977, USA

³Optical Communications R&D Laboratories, Sumitomo Electric Industries, 1, Taya-cho, Sakae-ku, Yokohama 244-8588, Kanagawa, Japan.

Roland.Ryf@alcatel-lucent.com

Abstract: We experimentally demonstrate multiple-input-multiple-output transmission of a combined 3-space-, and 2-polarization-, and 5-wavelength-division multiplex in a 3-core microstructured fiber over 4200 km. This is the record transmission distance for spatial-division multiplexing in a fiber.

OCIS codes: 060.4510, 060.1660, 060.2280, 040.1880, 060.4230.

1. Introduction

The knowledge of an impending nonlinear capacity limit of single-mode fiber [1] has sparked a renewed interest in spatial multiplexing over multicore [2], multimode [3], and microstructured fibers [4]. In single-mode fiber transmission with coherent detection, 2×2 multiple-input multiple-output (MIMO) digital signal processing (DSP) is necessary to recover the two polarization states. For space-division multiplexing (SDM), two scenarios are possible. The first requires fibers with very low crosstalk between spatial modes so that each spatial mode can be separately detected, while the second scenario allows for arbitrary mixing between spatial modes and requires MIMO on all spatial and polarization modes, and achieves higher spatial mode densities.

For uncoupled-mode transmission, the maximum reach achieved with polarization-division-multiplexed quadrature-phase-shift keying (PDM-QPSK) is 2688 km using an uncoupled 7-core fiber [2] while for fibers exhibiting spatial mode coupling, the maximum reach achieved is 137 km [3] for a few-mode fiber and 1200 km for a 3-core microstructured fiber (3C-MSF), both for single-wavelength PDM channel. In this paper, we demonstrate transmission of 6 spatial and polarization modes, 5 wavelength-division multiplexed (WDM) 40-Gbit/s QPSK signals on a 50-GHz grid, offering an aggregate single fiber capacity of 1.2 Tbit/s in a 250-GHz bandwidth and an aggregate per-fiber spectral efficiency of 4.03 b/s/Hz.

To compare the potential of various fibers, we define a *spatial spectral efficiency* $SSE = SE/(MA)$ where SE is the aggregate per-fiber spectral efficiency including all M spatial and polarization modes and A is the transverse area occupied by each mode. In the limit of a large number of densely packed cores, A is approximately given by $\sqrt{3}d^2/8$, where d is the distance between the cores. The maximum achievable SSE of our MSF is 3684 b/s/Hz/mm² for 4200-km transmission with 19.2% forward-error correction (FEC) overhead while, for the only other long-haul experiment using SDM in fibers [2], $SSE = 2259$ b/s/Hz/mm² for a shorter 2688-km distance of transmission (same FEC overhead). The experiment reported here is the a record MIMO SDM transmission distance and features a potential for high spatial spectral efficiency.

2. The three-core microstructured fiber

The design of the 3C-MSF consists of three homogeneous cores with 12.4- μ m diameter and a refractive index difference $\Delta = 0.27\%$, resulting in a large core effective area of (129 ± 2) μ m². Attenuation in a 60-km fiber was measured to be 0.181 dB/km at 1550 nm, which was measured by launching light into a single core and receiving the output power of all cores. The cutoff wavelength was designed to be around 1350 nm and chromatic dispersion and dispersion slope were designed to be 21 ps/nm/km and ~ 0.06 ps/nm²/km, respectively, at 1550 nm. The cores were embedded in a standard cladding diameter of 125 μ m, and the distance between the equidistant cores and the center of the fiber is 17 μ m, resulting in a distance between the cores of 29.4 μ m. A cross-section of the fiber profile is shown in Fig. 1 c). The crosstalk between cores was measured using a depolarized broadband source in order to avoid the strong multi-path interference present in the fiber. After 60 km of fiber, the crosstalk is so large that when sending light into a single core, the power is equally distributed across all cores at the end of the fiber. In the presence of such strong crosstalk, the light propagation in the fiber can be best described by their so called “super-modes” [5, 6], which are the modes of the composite fiber structure. As described in [4], the super-modes of a 3-core fiber have the same symmetry

structure as in a few-mode fiber (FMF) with 6 spatial and polarization modes, which are generally described by the linearly-polarized LP_{01} and the twofold degenerate LP_{11} pseudo mode, in fact, both the 3C-MSF and the 6-mode FMF are just two different designs of an equivalent multimode waveguide. The 3C-MSF offers the advantage of smaller DGD, compared to currently available FMF [7, 8]. Further reducing the core spacing and core diameter in the 3C-MSF is required in order to obtain a balanced comparison between the two fiber types.

One distinct advantage of the 3C-MSF is that a simple and low-loss mode coupler (CMUX) can be used to excite the diverse modes. The CMUX mainly consists of 3 collimators with a nominal beam diameter of $500 \mu\text{m}$ and a double telecentric imaging system formed by a lens pair with a focal length of 75 mm and 2.99 mm, respectively. The light spots produced by the collimators are then imaged on the end facet of the fiber. The resulting CMUX has an insertion loss of $< 2\text{dB}$. Although our CMUX does not directly excite individual super-modes, the CMUX can be described by a unitary transformation that homogeneously distributes the total power of each transmitted channel across all super-modes.

3. Coherent MIMO based parallel-loop experiment

The long distance performance of the 3C-MSF fiber is measured in a recirculating loop experiment as shown in Fig. 1 a). The WDM transmitter consists of 5 wavelengths produced by a corresponding number of distributed feed-

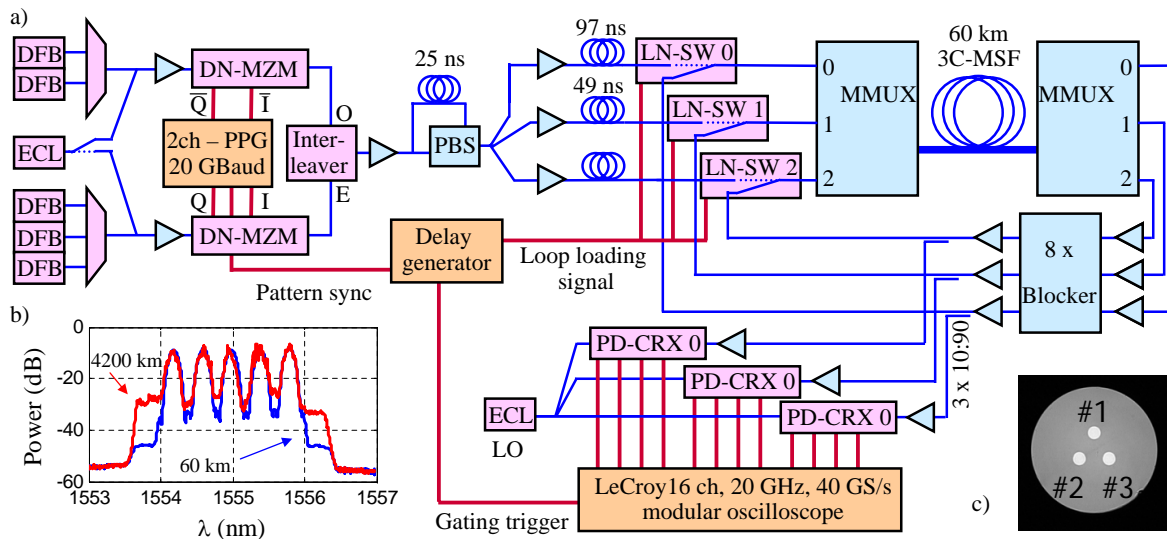

Fig. 1. a) Experimental set-up. PBS: Polarization beam splitter; triangles denote EDFAs. b) Power spectra after 60 and 4200 km transmission. c) Cross-section of the 3C-MSF.

back lasers (DFBs) aligned on a 50-GHz grid centered around 1555 nm, and the channel under test was an external cavity laser (ECL). The DFBs are arranged in two groups with odd and even channel numbers, which are combined with a wavelength multiplexer. Each group is modulated by a different double-nested Mach-Zehnder modulator (DN-MZM) insuring decorrelated first neighbors wavelength channels. Quadrature-phase-shift-keying (QPSK) with a symbol rate of 20 GBaud is used as a modulation format and two independent De Bruijn bit sequences (DBBS) of length 2^{12} are used for the in-phase (I) and quadrature (Q) components of the QPSK signal. The two groups of wavelength channels are then combined by an interleaver, and two time-delayed copies are generated with a polarization-multiplexing stage with a relative delay of 25 ns. The signal is subsequently split in three paths and relative delays of 97 ns and 49 ns are introduced. The three delayed copies are then fed to three LiNbO_3 switches (LN-SWs) that control the loading of a threefold recirculating loop. The loop consists of a pair of spatial-mode multiplexers (MMUXs) connected by a 60-km 3C-MSF, and 3 two-stage Erbium-doped fiber amplifiers (EDFAs), where a multichannel blocker is inserted between amplification stages in order to spectrally equalize the power in the loop. Finally, three 10/90 couplers are used to extract the signals from the loop which are detected with three polarization-diverse coherent receivers (PD-CRX). Note that the three paths of the triple loop have to be accurately aligned in order to avoid introduction of delays between loop paths. The relative length of the loop was accurately tuned to within $< 50 \text{ ps}$ using optical delay lines. The 3×4 electrical signals generated by the three PD-CRXs are then acquired on a fully-synchronized LeCroy LabMaster 9zi modular digital-storage oscilloscope operating at a sampling rate of 40 GSamples/s with a bandwidth of 20 GHz. The receivers are operated in an intradyne configuration with a free-running local oscillator (LO) from an ECL. Transmit

laser and ECL were aligned to within ± 20 MHz. A delay generator was controlling the 2-ms loop load time and also generating the trigger and gate signal for data acquisition and optical spectra measurements. Up to 100 loop round trips were captured corresponding to a maximal distance of 6000 km. For such a large number of passes through the loop components, a large passband distortion can be observed, which is mainly introduced by the multichannel blocker. The effect is shown in Fig. 1 b) where the spectra of the WDM channels are shown after different propagation distances.

The transmitted signals were recovered using MIMO DSP as described in [9], where the number of equalizer taps N_{taps} was increased to 400. The algorithm is based on a 6×6 array of feed-forward equalizers (FFE), where the FFE coefficients were optimized using the least mean square (LMS) algorithm which was extended with a phase tracking method based on the fourth-power algorithm. The algorithm is operated in data-aided mode for the first 450,000 symbols in order to obtain rapid convergence and then switches to decision-directed mode for the rest of the frame. The bit-error ratio (BER) is evaluated over one million bits, for all 5 wavelength channels on a computer cluster. The Q factors obtained from the BERs are plotted in Fig. 2 a) as a function of distance and for different optical power level as launched into each wavelength and spatial and polarization mode.

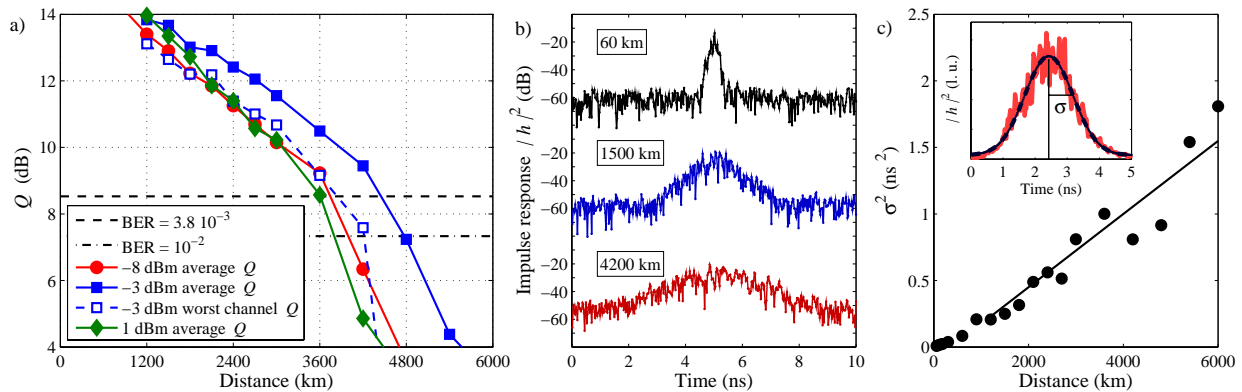

Fig. 2. a) Q factor as a function of distance for transmission over 3C-MSF; b) Squared magnitude of the impulse response h plotted on a log scale for three distances and -3 dBm power; c) Evolution of the variance σ^2 of $|h|^2$ based on a Gaussian fit (inset) of the pulse width as a function of distance, along with a linear fit.

As seen in Fig. 2 a), a Q-factor > 7.2 dB representing the limit tolerable for state-of-the-art 20% overhead hard-decision FEC of 1×10^{-2} can be maintained up to 4200 km for the worst spatial, polarization and wavelength channel Q at the best launch power of -3 dBm. Fig. 2 b) shows the square of the impulse response h as obtained from channel estimation described in [7] and after electronic dispersion and frequency-offset compensation for a few transmission distances. Fig. 2 c) shows the evolution of the variance of the width of $|h|^2$ obtained by a Gaussian fit. The linear fit suggests a complete randomization of the time delays between the cores during propagation.

4. Conclusion

We have demonstrated a record transmission distance of 4200 km and a record spatial spectral efficiency using a three-core microstructured fiber and 6-space- and polarization- and 5-wavelength-division multiplexed 40-Gbit/s channels, resulting in an aggregate capacity of 1.2 Tbit/s over a 250-GHz bandwidth. This experiment unequivocally demonstrates the potential of microstructured fibers in combination with MIMO digital signal processing for long-haul transmission.

We thank G. Raybon, C. Xie, and S. Chandrasekhar for support with the experiment.

References

1. R.-J. Essiambre et al., "Capacity limits of optical fiber networks," *J. Lightwave Technol.*, pp. 662-701 (2010).
2. S. Chandrasekhar et al., "WDM/SDM transmission of 10 x 128-Gb/s ...," *ECOC PD Th.13.C.4*, 2011.
3. R. Ryf et al., "Mode-equalized distributed Raman amplification in 137-km ...," *ECOC PD Th.13.K.5*, 2011.
4. R. Ryf et al., "Coherent 1200-km 6 x 6 MIMO ... 3-core microstructured fiber," *ECOC PD Th.13.C.1*, 2011.
5. R. Black and L. Gagnon, "Optical waveguide modes: polarization, coupling and symmetry," McGraw-Hill, 2009.
6. C. Xia et al., "Supermodes for optical transmission," *Opt. Express*, vol. 19, pp. 16 653–16 664, 2011.
7. R. Ryf et al., "Mode-division multiplexing over 96 km ...," *J. Lightwave Technol.*, Vol. 30, pp. 521-531, 2012.
8. E. Ip et al., "88 x 3 x 112-Gb/s WDM transmission over 50 km of three-mode ...," *ECOC PD Th.13.C.2*, 2011.
9. S. Randel et al., "6x56-Gb/s mode-division multiplexed ...," *Opt. Express*, vol. 19, pp. 16 697–16 707, 2011.