



Stingray

F-046



- Versatile 0.5 MP camera
- Advanced feature set
- Many variants
- Excellent image quality

Description

IEEE 1394b camera - Sony ICX415

The Stingray F-046B/F-046C is a IEEE 1394b camera with a sensitive Sony ICX415 HAD CCD sensor, and runs at 61 frames per second at full resolution. Thanks to its comprehensive image pre-processing functions, it delivers an outstanding high image quality.

Options:

- IEEE 1394b connectors: 2 x copper (daisy chain), Hirose power: out
- Various IR cut/pass filters, various lens mounts
- Angled head, board level version, white medical housing

Specifications

| Stingray | F-046 |
|------------------------------------|---|
| Interface | IEEE 1394b - 800 Mb/s, 2 ports, daisy chain |
| Resolution | 780 (H) × 580 (V) |
| Sensor | Sony ICX415 |
| Sensor type | CCD Progressive |
| Sensor size | Type 1/2 |
| Pixel size | 8.3 μm x 8.3 μm |
| Lens mount (default) | C-Mount |
| Max. frame rate at full resolution | 61 fps |
| ADC | 14 bit |
| Image buffer (RAM) | Up to 128 MByte |

Output

| Stingray | F-046 |
|---|--|
| Bit depth | 8-14 bit |
| Monochrome pixel formats | Mono8, Mono12, Mono16 |
| RGB color pixel formats | RGB8 |
| Raw pixel formats | Raw8, Raw12, Raw16 |
| General purpose inputs/outputs (GPIOs) | |
| Opto-isolated I/Os | 2 inputs, 4 outputs |
| RS232 | 1 |
| Operating conditions/dimensions | |
| Operating temperature | +5 °C to +45 °C |
| Power requirements (DC) | 8 V to 36 V |
| Power consumption | <4 W (@ 12 VDC) |
| Mass | 92 g |
| Body dimensions (L × W × H in mm) | 72.9 × 44 × 29 (including connectors) |
| Regulations | CE: 2014/30/EU (EMC), 2011/65/EU (RoHS); FCC Class B |

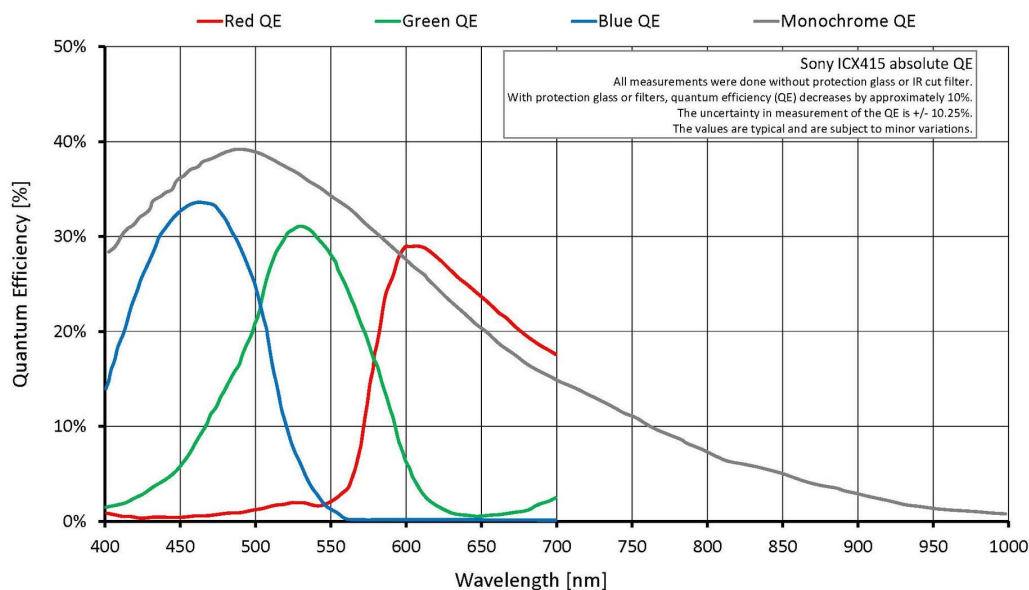

Features

- High SNR mode (up to 24 dB better signal-to-noise ratio)
- Low-noise binning mode
- Shading correction
- Defect pixel correction
- Area of interest (AOI), separate AOI for auto features



- Binning
- Decimation
- Auto gain (manual gain control: 0 to 24.4 dB)
- Auto exposure (31 μ s to 67 s)
- Auto white balance
- Look-up table (LUT)
- Hue, saturation
- Color correction
- Local color anti-aliasing
- Reverse X/Y
- Deferred image transport
- Trigger programmable, level, single, bulk, programmable delay
- Sequence mode (changes the camera settings on the fly)
- SIS (secure image signature, time stamp for trigger, frame count etc.)
- Storable user sets

Scope of delivery

- Camera and IEEE 1394b cable (other configurations on request)

Technical drawing

2 x 1394b copper

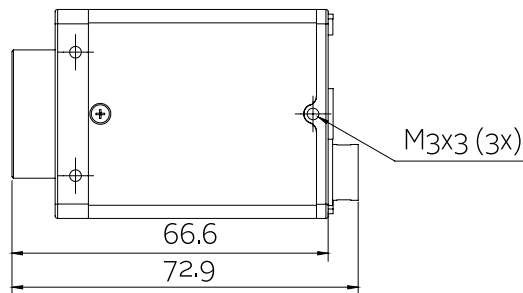
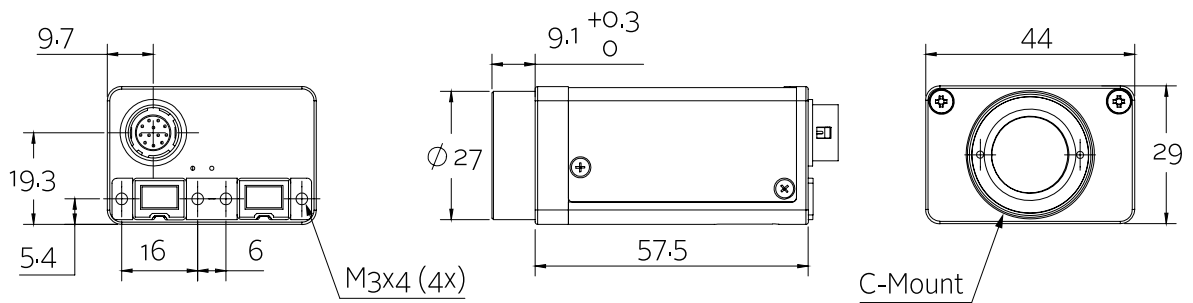
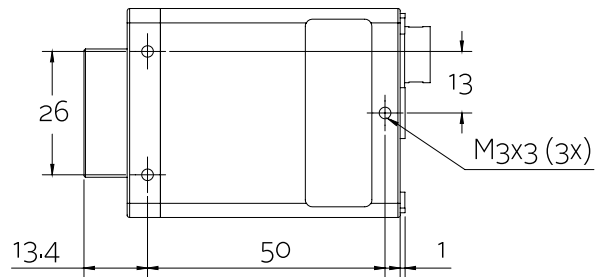



Applications

The Stingray F-046B/F-046C includes comprehensive image pre-processing functions. It is only mid-priced, but performs with high image quality. This 0.5 Megapixel IEEE 1394b camera is suitable for applications with high demands:

- Industrial inspection and automation
- Logistics
- Science and research
- Healthcare and medical (white housing available)
- Multimedia, entertainment and sports
- Intelligent traffic solutions (ITS)

Additionally, it is ideally suited for:

- Demanding OEM camera applications (board level versions with separate sensor board available on request)
- Daisy chaining (two copper connectors)