



# Goldeye

## G-008 TEC1

- Affordable GigE Vision InGaAs SWIR camera
- QVGA resolution
- Power over Ethernet
- Compact industrial design, no fan

### Goldeye G-008 TEC1 - Affordable high-speed QVGA InGaAs camera

The Goldeye G-008 TEC1 is the fastest 1/4-VGA resolution short wave infrared camera (SWIR) with GigE Vision interface. With frame rates up to 344 fps at full resolution, versatile application fields can be addressed and processes can be sped up strongly. Thanks to its very affordable price, many cost-sensitive applications, where the lower resolution is sufficient, can benefit from the camera's outstanding performance.

Save time and money to integrate the camera into your system: a small form factor and multiple mounting options let the camera fit easily into compact system designs. Additionally, its standardized GigE Vision interface including Power over Ethernet and comprehensive I/O control options simplify the connection to your software solution and the synchronization with other system components.

The integrated thermo-electric sensor cooling and several on-board image correction features contribute to the Goldeye's outstanding image quality.

Reveal more of the invisible with Goldeye SWIR cameras!

#### Benefits and Features

- Compact industrial design
- Up to 344 fps at full resolution
- GigE Vision interface with PoE+
- Comprehensive I/O control options
- Automated on-board image correction
- Stabilized sensor-cooling, no fan
- Extended operating temperature range

## Hardware options

- Various lens mounts: Select between C-Mount, F-Mount, or M42-Mount

## Specifications

<b>Goldeye</b>	<b>G-008 TEC1</b>
Interface	IEEE 802.3 1000BASE-T, IEEE 802.3af (PoE)
Resolution	320 (H) × 256 (V)
Spectral range	900 nm to 1700 nm
Sensor	InGaAs FPA 320 × 256
Sensor type	InGaAs
Sensor size	No standard size
Pixel size	30 μm × 30 μm
Lens mounts (available)	M42-Mount, F-Mount, C-Mount
Max. frame rate at full resolution	344 fps
ADC	14 Bit
Image buffer (RAM)	256 MByte
<b>Imaging performance</b>	
Cooling temperature	+20 °C, +25 °C (default and calibrated), +35 °C, +50 °C, or user-configurable
Dark current	280 ke <sup>-</sup> /s (at +25 °C FPA temperature)
Temporal dark noise	420 e <sup>-</sup> (Gain0), 170 e <sup>-</sup> (Gain1)
Saturation capacity	2.5 Me <sup>-</sup> (Gain0), 170 ke <sup>-</sup> (Gain1)
Dynamic range	75 dB (Gain0), 60 dB (Gain1)
<b>Output</b>	
Bit depth	8 - 14 Bit
Monochrome pixel formats	Mono8, Mono12, Mono12Packed, Mono14
<b>General purpose inputs/outputs (GPIOs)</b>	
TTL I/Os	LVTTTL I/Os: 1 Input, 1 Output
Opto-isolated I/Os	1 Input, 2 Outputs
RS232	115 000 Baud, 8N1 (adjustable)
<b>Operating conditions/dimensions</b>	
Operating temperature	-20 °C to +55 °C (Case)
Power requirements (DC)	10.8 V to 30.0 V or via PoE
Power consumption	10.8 W (at 12 VDC), <12.95 W (PoE)
Mass	340 g (with C-Mount adapter)
Body dimensions (L × W × H in mm)	78 × 55 × 55
Regulations	CE: 2014/30/EU (EMC), 2011/65/EU, incl. amendment 2015/863/EU (RoHS); FCC Class B

## Quantum efficiency

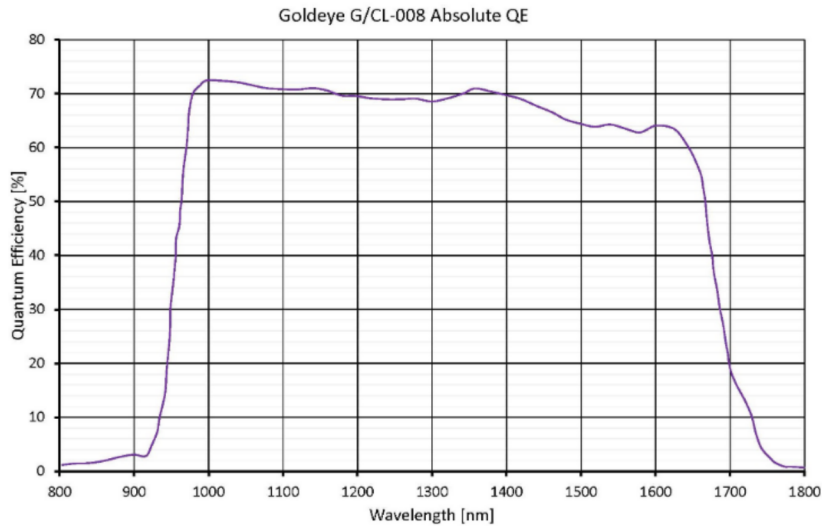

## Features

### IR-specific features (camera and sensor)

- Integrated correction data sets, compensation of sensor inhomogeneity and underlying structures (non-uniformity correction - NUC)
- Defect pixel correction
- Background correction
- Automated and manual sensor temperature management via TEC features
- Temperature status indicator
- Temperature specific events

### General features

- Automatic exposure time control
- Gain (analog)
- I/O configuration and trigger control
- Stream hold (deferred image output)
- Storable user sets
- Firmware update in the field
- Region of interest (ROI) control, Look-up table (LUT) support, as well as various Auto-Features



Goldeye cameras are compatible with Allied Vision's Vimba SDK. Moreover, in combination with our AcquireControl software, extensive image analysis functions are available:

- Pseudo color LUT with several color profiles
- Auto contrast
- Auto brightness
- Analyze multiple regions (rectangular, circle) within the image
- Real-time statistics and histogram display

## Technical drawing

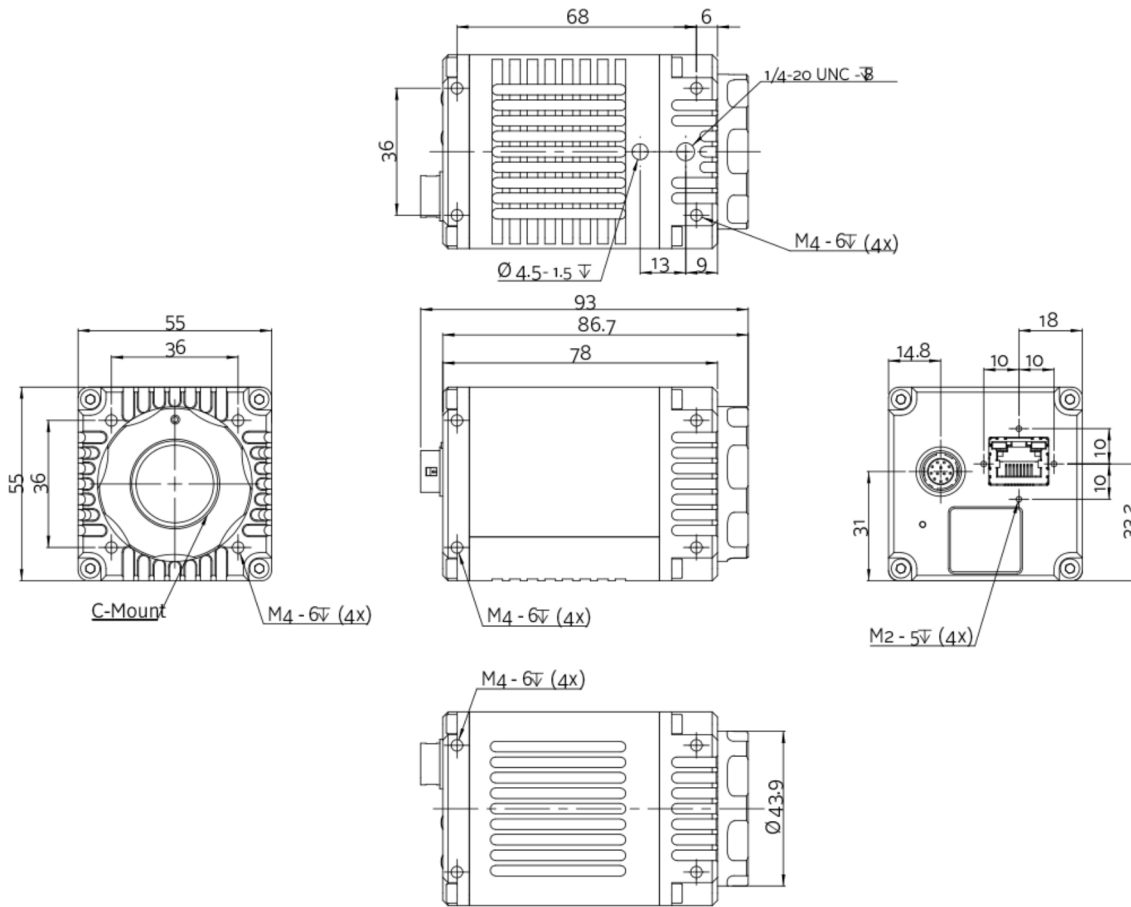

## Applications

Goldeye cameras are very sensitive in the SWIR spectrum. They can be used in an extended operating temperature range. Thanks to temperature stabilization and integrated image correction, Goldeye cameras achieve an outstanding image quality with little noise and a high dynamic range. They are well-suited for many typical SWIR applications in various industry branches:

- Semiconductor industry: solar cell and chip inspection
- Recycling industry: plastics sorting
- Medical imaging, sciences: hyperspectral imaging, microscopy, OCT
- Metal and glass industry: thermal imaging of hot objects (250 °C to 800 °C)
- Agriculture industry: airborne remote sensing
- Printing industry: banknote inspection
- Electronics industry: laser beam profiling
- Surveillance and security: vision enhancement (for example through fog or night vision)

### White Paper

To learn more about typical application fields for SWIR cameras, download our White Paper:

[Seeing beyond the visible – short-wave infrared \(SWIR\) cameras offer new application fields in machine vision](#)