



Goldeye

G-032 Cool TEC2

- Low noise GigE Vision InGaAs SWIR camera
- VGA resolution
- Power over Ethernet (PoE+)
- large pixel with high dynamic
- Strong sensor cooling, no condensation

Goldeye G-032 Cool TEC2 cooled VGA InGaAs camera

The Goldeye G-032 Cool TEC2 is a short-wave infrared camera that is optimized for scientific grade applications often requiring long exposure times. To enable low-noise imaging in the spectral range from 900 nm to 1700 nm the camera is equipped with a nitrogen filled cooling chamber and enables via the dual-stage thermo-electric cooler (TEC) a very strong sensor cooling of up to -60 °C towards the housing temperature.

The standardized GigE Vision interface and comprehensive I/O control options simplify the connection to many software solution and the synchronization with other system components.

In addition several automated on-board image correction features contribute to the Goldeye's outstanding image quality.

Reveal more of the invisible with Goldeye SWIR cameras!

Benefits and features

- Very strong sensor cooling for low-noise imaging with long exposure times
- GigE Vision interface with PoE+
- Comprehensive I/O control options
- Automated on-board image correction
- Extended operating temperature range

Hardware options

- Various lens mounts: Select between C-Mount, F-Mount, or M42-Mount

Specifications

Goldeye	G-032 Cool TEC2
Interface	IEEE 802.3 1000BASE-T, IEEE 802.3at (PoE+)
Resolution	636 (H) × 508 (V)
Spectral range	900 nm to 1700 nm
Sensor	InGaAs FPA 636 × 508
Sensor type	InGaAs
Sensor size	No standard size
Pixel size	25 μm × 25 μm
Lens mounts (available)	C-Mount, F-Mount, M42-Mount
Max. frame rate at full resolution	100 fps
Netd	256
ADC	14 Bit
Image buffer (RAM)	256 MByte
Imaging performance	
Cooling temperature	-20 °C (default and calibrated), -5 °C, +10 °C, or user-configurable
Dark current	30 ke ⁻ /s (at -20 °C FPA temperature)
Temporal dark noise	400 e ⁻ (Gain0), 170 e ⁻ (Gain1)
Saturation capacity	1.9 Me ⁻ (Gain0), 39 ke ⁻ (Gain1),
Dynamic range	73 dB (Gain0), 47 dB (Gain1),
Output	
Bit depth	8 - 14 Bit
Monochrome pixel formats	Mono8, Mono12, Mono12Packed, Mono14
General purpose inputs/outputs (GPIOs)	
TTL I/Os	LVTTL I/Os: 1 Input, 1 Output
Opto-isolated I/Os	1 Input, 2 Outputs
RS232	115 200 Baud, 8N1 (adjustable)
Operating conditions/dimensions	
Operating temperature	-20 °C to +55 °C (Case)
Power requirements (DC)	10.8 V to 30.0 V or via PoE+
Power consumption	19 W (at 12 VDC), 22 W (PoE+)
Mass	810 g (with C-Mount adapter)
Body dimensions (L × W × H in mm)	90 × 80 × 80
Regulations	CE: 2014/30/EU (EMC), 2011/65/EU, incl. amendment 2015/863/EU (RoHS); FCC Class B

Quantum efficiency

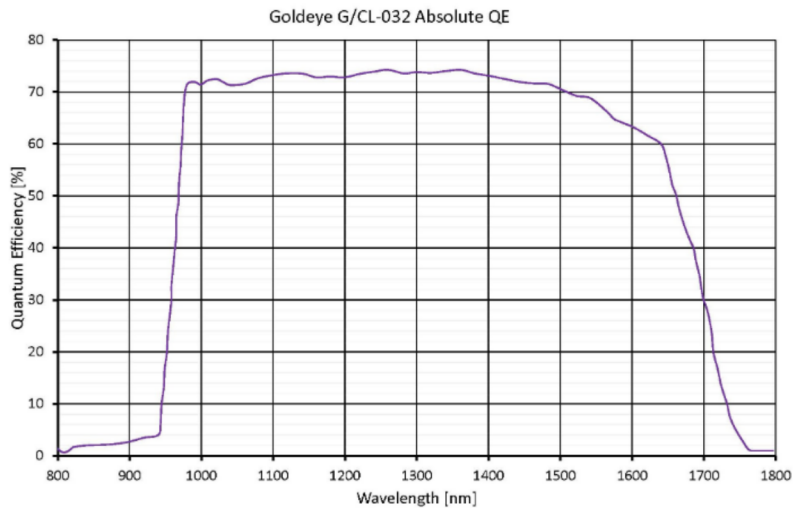

Features

IR-specific features (camera and sensor)

- Integrated correction data sets, compensation of sensor inhomogeneity and underlying structure (non-uniformity correction, NUC)
- Defect pixel correction
- Background correction
- Automated and manual sensor temperature management via TEC features
- Temperature status indicator
- Temperature specific events

General features

- Automatic exposure time control
- Gain (analog)
- I/O configuration and trigger control
- Stream hold (deferred image output)
- Storable user sets
- Firmware update in the field

Goldeye cameras are compatible with Allied Vision's Vimba SDK. Moreover, in combination with Allied Vision's AcquireControl software, extensive image analysis functions are available:



- Pseudo color LUT with several color profiles
- Auto contrast
- Auto brightness
- Analyze multiple regions (rectangular, circle) within the image
- Real-time statistics and histogram display

Technical drawing

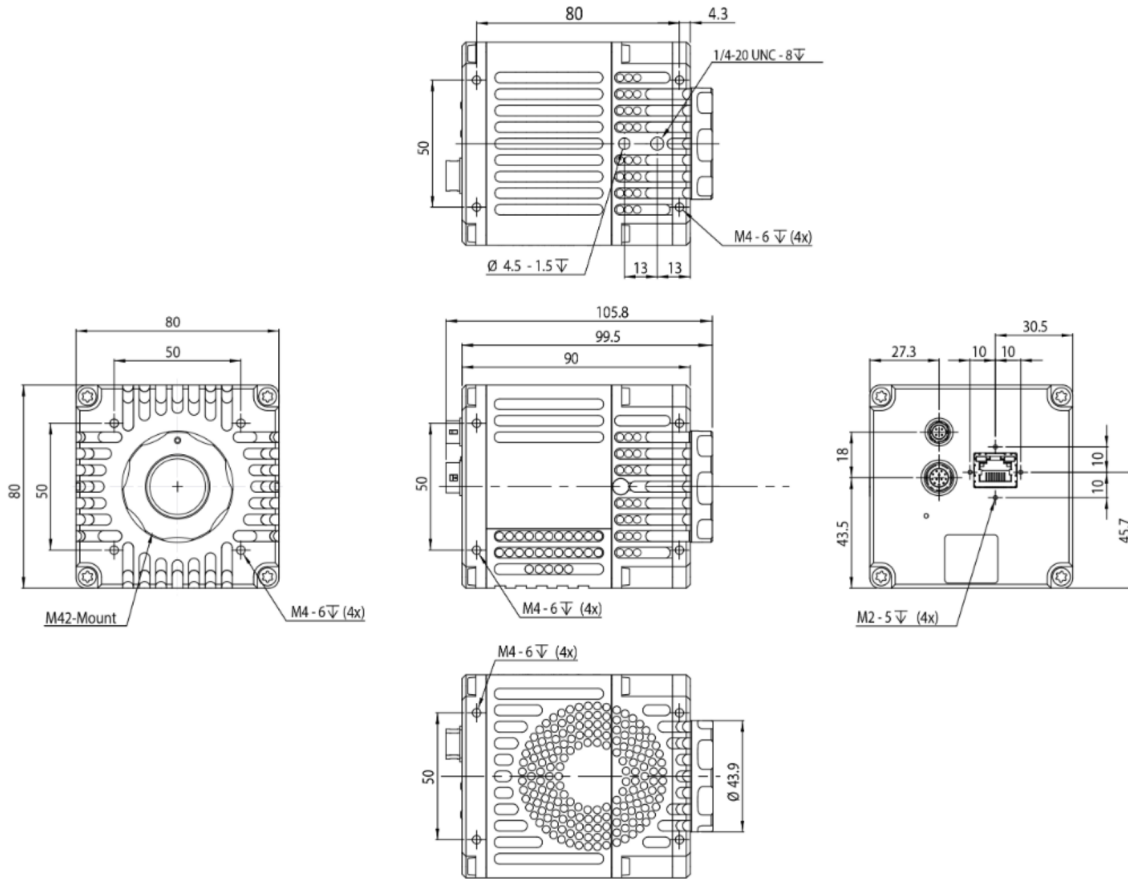

Applications

Goldeye cameras are very sensitive in the SWIR spectrum. They can be used in an extended operating temperature range. Thanks to TEC cooling and integrated image correction, Goldeye cameras achieve an outstanding image quality with little noise and a high dynamic range. They are well-suited for many typical SWIR applications in various industry branches:

- Semiconductor industry: solar cell and chip inspection
- Recycling industry: plastics sorting
- Medical imaging, sciences: hyperspectral imaging, microscopy, OCT
- Metal and glass industry: thermal imaging of hot objects (250 °C to 800 °C)
- Agriculture industry: airborne remote sensing
- Printing industry: banknote inspection
- Electronics industry: laser beam profiling
- Surveillance and security: vision enhancement (for example, through fog or night vision)

White Paper

To learn more about typical application fields for SWIR cameras, download our White Paper:

[Seeing beyond the visible – short-wave infrared \(SWIR\) cameras offer new application fields in machine vision](#)