



# Goldeye

## G-032 TEC1

- GigE Vision InGaAs SWIR camera
- VGA resolution
- Power over Ethernet
- large pixel with high dynamic
- Compact industrial design, no fan

### Goldeye G-032 TEC1 - VGA InGaAs camera with large pixel

The Goldeye G-032 TEC1 is a very versatile shortwave infrared camera for the spectral range from 900 nm to 1700 nm. High frame rates of 100 fps at full resolution (636 x 508), strong sensor cooling, as well as a high intra-scene dynamic range of more than 73 dB enable to apply the camera in various application areas and under varying operating conditions.

Save time and money to integrate the camera into your system: A small form factor and multiple mounting options let the camera fit easily into compact system designs. In addition, its standardized GigE Vision interface and comprehensive I/O control options simplify the connection to your software solution and the synchronization with other system components.

The integrated thermo-electric sensor cooling and several on-board image correction features contribute to the Goldeye's outstanding image quality.

Reveal more of the invisible with Goldeye SWIR cameras!

#### Benefits and features

- Compact industrial design
- GigE Vision interface with Power over Ethernet
- Very high intra-scene dynamic range of 73 dB
- Comprehensive I/O control options
- Automated on-board image correction
- Stabilized sensor cooling, no fan
- Extended operating temperature range

#### Hardware options

- Various lens mounts: Select between C-Mount, F-Mount, or M42-Mount

## Specifications

<b>Goldeye</b>	<b>G-032 TEC1</b>
Interface	IEEE 802.3 1000BASE-T, IEEE 802.3af (PoE)
Resolution	636 (H) × 508 (V)
Spectral range	900 nm to 1700 nm
Sensor	InGaAs FPA 636 × 508
Sensor type	InGaAs
Sensor size	No standard size
Pixel size	25 μm × 25 μm
Lens mounts (available)	C-Mount, F-Mount, M42-Mount
Max. frame rate at full resolution	100 fps
ADC	14 Bit
Image buffer (RAM)	256 MByte
<b>Imaging performance</b>	
Cooling temperature	+5 °C, +20 °C (default and calibrated), +35 °C, +50 °C, or user-configurable
Dark current	380 ke <sup>-</sup> /s (at +20 °C FPA Temperature)
Temporal dark noise	400 e <sup>-</sup> (Gain0), 170 e <sup>-</sup> (Gain1)
Saturation capacity	1.9 Me <sup>-</sup> (Gain0), 39 ke <sup>-</sup> (Gain1)
Dynamic range	73 dB (Gain0), 47 dB (Gain1)
<b>Output</b>	
Bit depth	8 - 14 Bit
Monochrome pixel formats	Mono8, Mono12, Mono12Packed, Mono14
<b>General purpose inputs/outputs (GPIOs)</b>	
TTL I/Os	LVTTL I/Os: 1 Input, 1 Output
Opto-isolated I/Os	1 Input, 2 Outputs
RS232	115 200 Baud, 8N1 (adjustable)
<b>Operating conditions/dimensions</b>	
Operating temperature	-20 °C to +55 °C (Case)
Power requirements (DC)	10.8 V to 30.0 V or via PoE
Power consumption	10.8 W at 12 VDC; <12.95 W PoE
Mass	370 g (with C-Mount adapter)
Body dimensions (L × W × H in mm)	78 × 55 × 55
Regulations	CE: 2014/30/EU (EMC), 2011/65/EU, incl. amendment 2015/863/EU (RoHS); FCC Class B

## Quantum efficiency

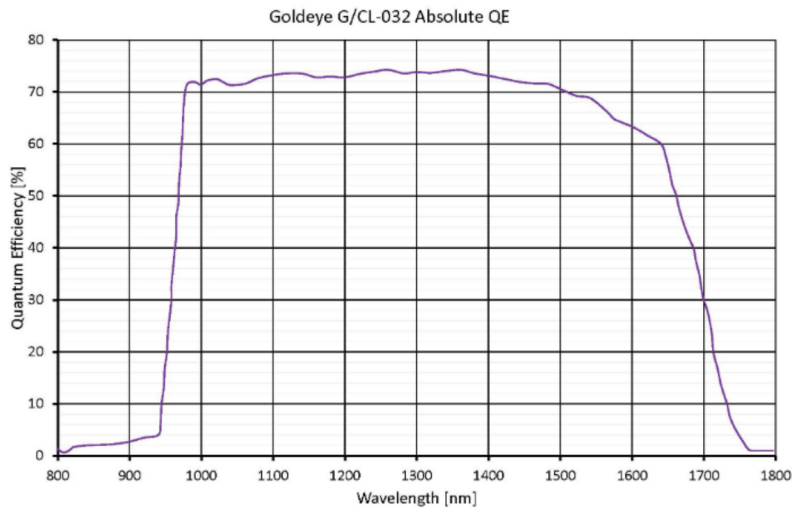

## Features

### IR-specific features (camera and sensor)

- Integrated correction data sets, compensation of sensor inhomogeneity and underlying structures (non-uniformity correction - NUC)
- Defect pixel correction
- Background correction
- Automated and manual sensor temperature management via TEC features
- Temperature status indicator
- Temperature specific events

### General features

- Automatic exposure time control
- Gain (analog)
- I/O configuration and trigger control
- Stream hold (deferred image output)
- Storable user sets
- Firmware update in the field
- Region of interest (ROI) control, Look-up table (LUT) support, as well as various Auto-Features



Goldeye cameras are compatible with Allied Vision's Vimba SDK. Moreover, in combination with our AcquireControl software, extensive image analysis functions are available:

- Pseudo color LUT with several color profiles
- Auto contrast
- Auto brightness
- Analyze multiple regions (rectangular, circle) within the image
- Real-time statistics and histogram display

## Technical drawing

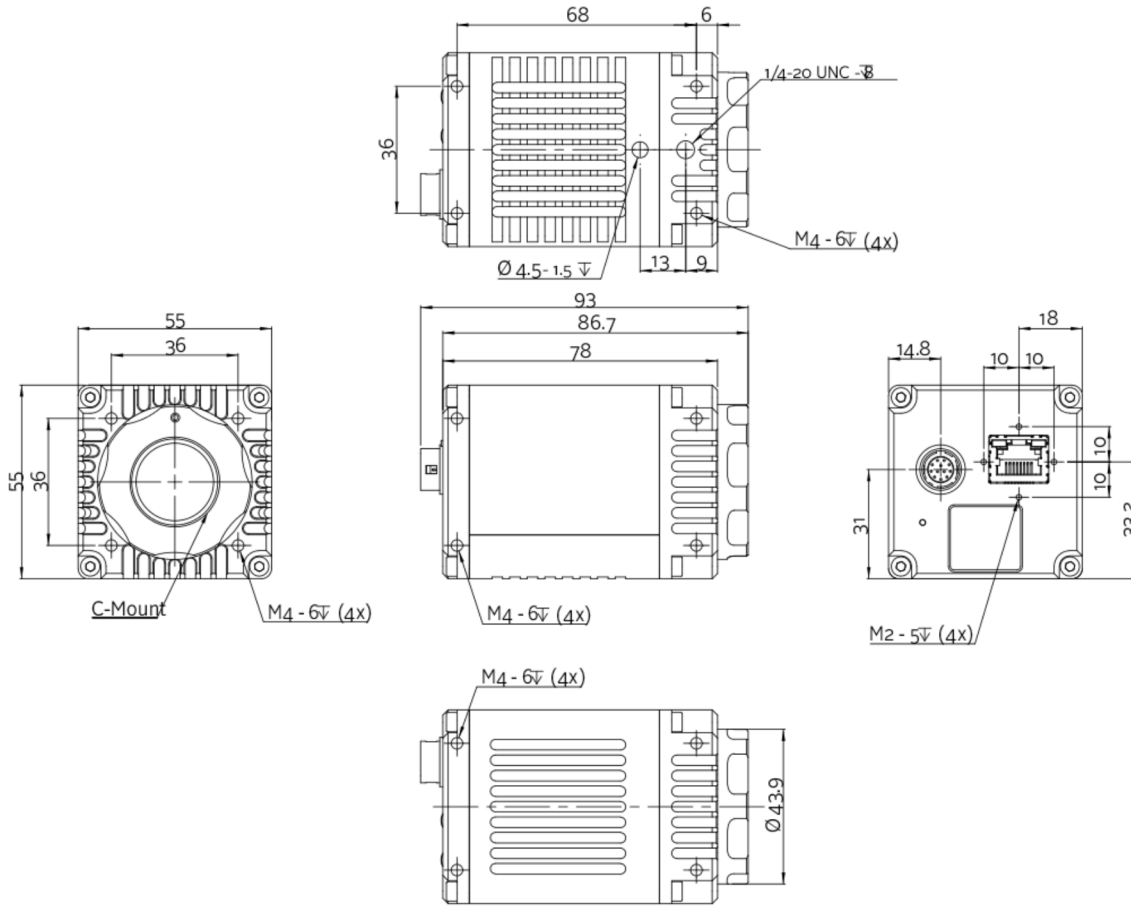

## Applications

Goldeye cameras are very sensitive in the SWIR spectrum. They can be used in an extended operating temperature range. Thanks to temperature stabilization and integrated image correction, Goldeye cameras achieve an outstanding image quality with little noise and a high dynamic range. They are well-suited for many typical SWIR applications in various industry branches:

- Semiconductor industry: solar cell and chip inspection
- Recycling industry: plastics sorting
- Medical imaging, sciences: hyperspectral imaging, microscopy, OCT
- Metal and glass industry: thermal imaging of hot objects (250 °C to 800 °C)
- Agriculture industry: airborne remote sensing
- Printing industry: banknote inspection
- Electronics industry: laser beam profiling
- Surveillance and security: vision enhancement (for example, through fog or night vision)

### White Paper

To learn more about typical application fields for SWIR cameras, download our White Paper:

[Seeing beyond the visible – short-wave infrared \(SWIR\) cameras offer new application fields in machine vision](#)