

High Power Probes

High-voltage/Current Probes and Accessories

Overview

Cascade high-power probes from FormFactor provide a complete on-wafer solution for over-temperature, low-contact resistance measurements of power semiconductors. Together with the TESLA series of on-wafer power device characterization, FormFactor's high-power probes achieve reliable and repeatable on-wafer measurements up to 600 A and 10,000 V.

Safety Notice: The probes discussed within this data sheet are designed to be used on FormFactor TESLA on-wafer power device characterization systems that incorporate a safety enclosure, safety interlocks and other features required for the safe use of these types of probes. These probes are only meant to be used on TESLA systems or probing systems that have the same or substantially equivalent safety features. If there is any uncertainty with regard to the safety requirements for your application of these types of products or the safety features of your probing system(s), please consult with your company's safety officials.

High-Power Probe Selection Guide

	UHP	HCP		HVP			
		HCP-1B	HCP-BNC	HVP-3T	HVP-3C	HVP-5C	HVP-10C
Max pulsed current	Up to 300 A	100 A	40 A	2 A*	5 A*	5 A*	3 A*
Voltage	Up to 10,000 V	500 V	500 V	3,000 V (Triax)	3,000 V (Coax)	5,000 V (Coax)	10,000 V (Coax)
Typical probe body residual resistance	≤ 5 mΩ	10 mΩ	10 mΩ	200 mΩ	30 mΩ	30 mΩ	100 mΩ
Probe configuration	Single, Parallel	Single, Parallel	Single	Single	Single	Single	Single
Typical pad material**	AlSiCu, AlSi, Al	AlSiCu, AlSi, Al, Au***	AlSiCu, AlSi, Al, Au***	AlSiCu, AlSi, Al, Au***	AlSiCu, AlSi, Al, Au***	AlSiCu, AlSi, Al, Au***	AlSiCu, AlSi, Al, Au***
Connector type	HV Banana plug	Single Banana plug	BNC	Keysight HV Triax	Coaxial (SHV)	Coaxial (SHV)	Coaxial (UHV)
Replaceable tip	Yes	Yes	Yes	Yes	Yes	Yes	Yes
Configurable tip	Yes	As Special Request	As Special Request	No	No	No	No

*Max Pulsed Current depends on PTT tip size. Showing current values are using PTT-120 tip.

**For HVP probes, different needle types available depending on the pad materials. Please contact FormFactor for more information.

***Can be used on Au with BeCu Tips.

> UHP Probe

FormFactor's Ultra-High-Power Probe (UHP), a high-voltage parametric probe, handles both high voltage (up to 10,000 V) and high current (up to 600 A) at a wide temperature range (-60°C to 300°C).

The high pulse current achieves full I-V characterization with one setup and one touchdown. Together with a TESLA on-wafer power device characterization system, the UHP fully utilizes the high-voltage/current capability of Keysight B1505A and N1265A Ultra High Current Expander.

- Coaxial measurements up to 10,000 V and 300 A pulsed (30 A DC), without the need for multiple probes and multiple measurement setup changes
- Innovative multi-finger tip design to achieve even distribution of current and minimize pad damage
- Probe current can be doubled up to 600 A when using double probe configuration
- Highly reliable, stable and repeatable measurements with Keysight B1505A and N1265A Ultra High Current Expander
- Typical probe lifetime is over 100,000 touchdowns under high-current test conditions



UHP Probe Holder

Maximum voltage	10,000 V DC at 200°C, 8,000 V at 300°C
Maximum current	300 A pulse (600 A in a parallel configuration) / 30 A DC
Operating temperature range	-60°C to 300°C
Connector type	High-voltage Banana (4 mm)
Length of cable	1 m
Positioner compatibility	RPP304
Probe residual resistance	≤ 5 mΩ
Probe insulation resistance	> 10 TΩ at 25°C (chuck temperature) > 3 TΩ at 200°C (chuck temperature) > 1 TΩ at 300°C (chuck temperature)

> Physical Dimensions

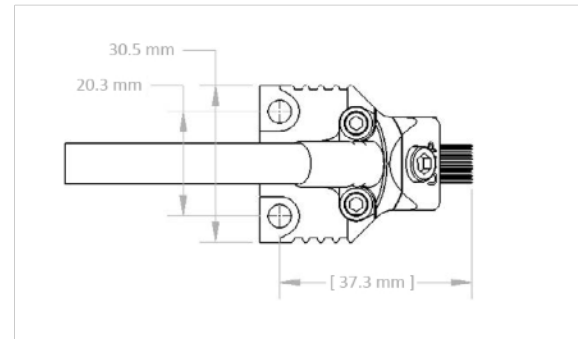
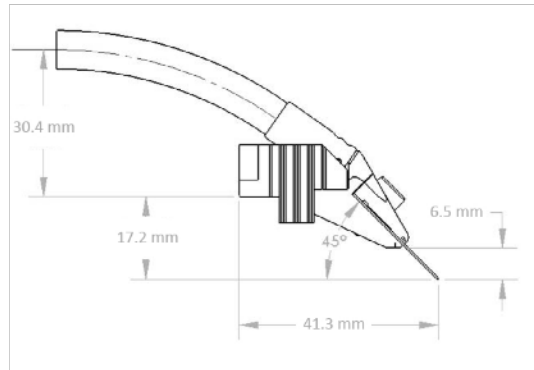
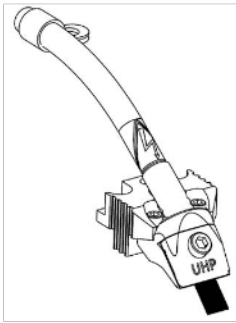

UHP Probe Tips

Typical contact resistance on AISiCu	< 2 mΩ (AISiCu metal layer) for 12 fingers < 3 mΩ (AISiCu metal layer) for 8 fingers tip < 6 mΩ (AISiCu metal layer) for 4 fingers tip < 30 mΩ (AISiCu metal layer) for 1 fingers tip	
Tip material	Tungsten	
Recommended range of overtravel	125 μm to 250 μm	
Scrub	~150 μm (at 250 μm to 400 μm overtravel)	
Finger width	250 μm	
Finger pitch	650 μm	
Probe tip layouts	12 fingers (300 A)	7400 μm width
	8 fingers (200 A)	4800 μm width
	4 fingers (100 A)	2200 μm width
	1 finger (25 A)	250 μm width

> HCP Probe

FormFactor's High-Current Probe (HCP) reduces probe and/or device destruction at high currents. It supports 10 A DC and up to 100 A of pulsed current. By design, the probe tip minimizes contact resistance at the wafer-to-probe interface to prevent device heating at the tip.

The innovative multi-finger probe tip design distributes current evenly over multiple contact points and is joined by a single heat sink that pulls heat from the probe tip.

- Minimal contact resistance at the pad-tip junction to reduce heating during measurements, with fewer probe marks
- Measure devices on wafer at high-current conditions over a wide temperature range (-60°C to 300°C)
- Small scrub minimizes damage on Al pad
- Small footprint tip for small pad probing down to 1 mm x 1 mm pad
- Typical probe lifetime is over 100,000 touchdowns under high-current test conditions



HCP Probe Holder

Maximum voltage	500 V DC
Maximum current (pulse)	100 A, 1 msec max PW, 1% max duty cycle (high-voltage Banana plug) 40 A, 1 msec max PW, 1% max duty cycle (BNC)
Maximum current (DC)	10 A
Total resistance with tip	10 mΩ (typical)
Operating temperature range	-60°C to 300°C
Isolation resistance	> 100 GΩ at 500 V
Connector type	High-voltage Banana (4 mm) or BNC
Length of cable	1 m high-voltage Banana (4 mm) / 0.76 m BNC
Positioner compatibility	RPP304

> Physical Dimensions

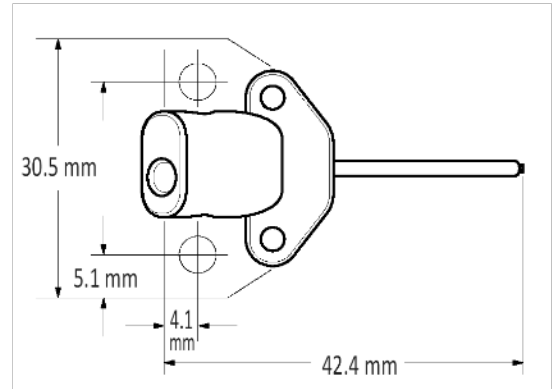
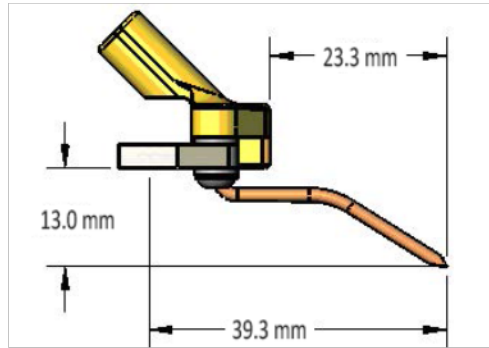
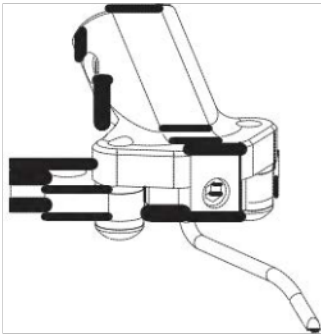

UHP Probe Tips

Typical contact resistance on Al	20 mΩ
Tip material	Tungsten
Recommended range of overtravel	75 μm to 125 μm
Contact force	20 grams per tip (60 grams total) at 100 μm overtravel
Scrub	250 μm to 400 μm

Typical Scrub Mark on Al Pads

The TESLA system HCP probe has been specifically designed for the purpose of minimizing contact resistance, while reducing the amount of probe damage and/or destruction of the device under test. Pictured here is a typical scrub mark on Al pads.

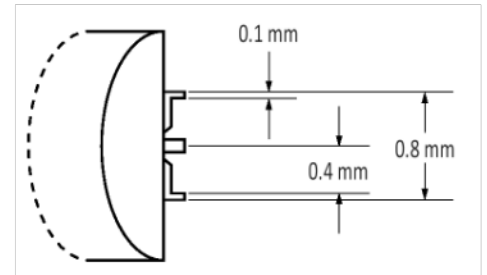
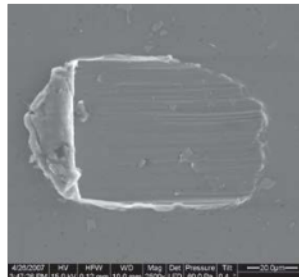

> HVP Probe

To ensure precision measurements of today's high-voltage devices, FormFactor's High-Voltage Probes (HVP) provide increased isolation resistance and dielectric strength by incorporating advanced internal isolation materials, as well as custom cabling and connectors.

When used with a TESLA on-wafer characterization system, the HVP assures low-noise electrical performance and full triaxial capability at high voltage without any breakdowns.

- Accurate coaxial and triaxial measurements up to 10,000 V for a much better understanding of device leakage in the off state
- Highly reliable, stable and repeatable measurements over a wide temperature range (-60°C to 300°C)
- Field-replaceable tips available in a variety of diameters to accommodate device dimensions



HVP Probe Holder

Maximum voltage guarded (triaxial)	3,000 V DC
Maximum voltage unguarded (coaxial)	10,000 V DC
Maximum current	5 A pulse / 1 A DC
Operating temperature range	-60°C to 300°C
Isolation resistance (force to guard)	> 1 TΩ at 3,000 V
Typical residual capacitance (with PTT needle)	< 0.5 pF
Cable characteristics	Approximately 50 Ω (48 Ω)
Connector type	SHV, UHV, or Keysight high-voltage triaxial connector (connector may limit maximum voltage performance)
Replaceable tip type	Straight PTT style needles
Recommended range of overtravel	50 μm to 100 μm
Scrub	20 μm to 40 μm
Positioner compatibility	DPP series positioners

> Physical Dimensions

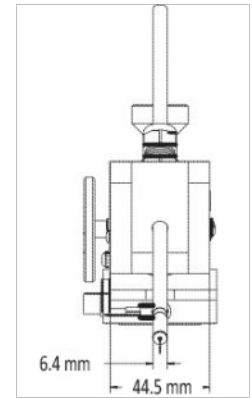
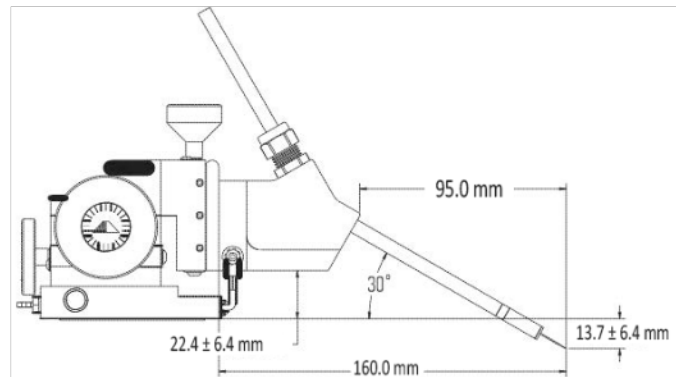
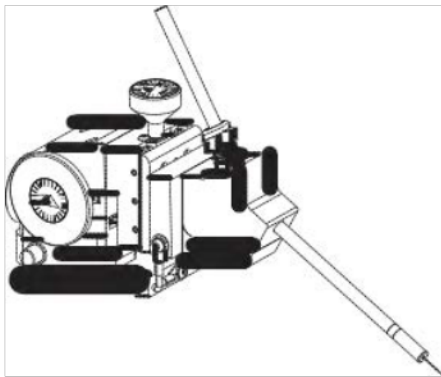

Typical High-Voltage Triaxial Probe Noise (HVP-3T)

	10 V				3,000 V			
	- 55°C	25°C	200°C	300°C	- 55°C	25°C	200°C	300°C
Temperature	- 55°C	25°C	200°C	300°C	- 55°C	25°C	200°C	300°C
Noise	30 fA	30 fA	30 fA	30 fA	100 fA	100 fA	100 fA	100 fA

Typical High-Voltage Coaxial Probe Leakage (HVP-3C)

	10 V				3,000 V			
	- 55°C	25°C	200°C	300°C	- 55°C	25°C	200°C	300°C
Temperature	- 55°C	25°C	200°C	300°C	- 55°C	25°C	200°C	300°C
Noise	≤ 10 pA	≤ 10 pA	≤ 10 pA	≤ 10 pA	≤ 200 pA	≤ 200 pA	≤ 200 pA	≤ 200 pA

➤ Regulatory Compliance

CE

➤ Ordering Information

Consult factory for more detailed specifications, additional options, suitability of configuration for intended usage, part numbers, pricing, and delivery.

© Copyright 2023 FormFactor, Inc. All rights reserved.
FormFactor and the FormFactor logo are trademarks
of FormFactor, Inc. All other trademarks are the property
of their respective owners.

All information is subject to change without notice.

HIGHPOWERPROBES-DS-0223

Corporate Headquarters
7005 Southfront Road
Livermore, CA 94551
Phone: 925-290-4000
www.formfactor.com