

# Manta

## G-1236



- Sony IMX304 CMOS sensor
- Power over Ethernet option
- Angled-head and board level variants
- Video-iris lens control

## GigE Vision camera with the Sony IMX304 CMOS sensor

Manta G-1236 is a 12.4 megapixel machine vision camera with a GigE compliant Gigabit Ethernet port and Hirose I/O port. Manta G-1236 incorporates the high quality Type 1.1 (17.6 mm diagonal) Sony IMX304 CMOS sensor with Pregius global shutter technology. At full resolution, this camera runs 9.7 frames per second. With a smaller region of interest, higher frame rates are possible. The Manta G-1236 is an ideal replacement for legacy CCD models.

Manta is one of Allied Vision's versatile GigE Vision cameras with a wide range of features. Particular highlights are the three look-up tables, sophisticated color correction capabilities, a robust metal housing, and many modular options. By default monochrome models ship with B 270 protection glass and color models ship with a Type Hoya C-5000 IR cut filter.

### Benefits and features

- Monochrome (G-1236B) and color (G-1236C) models
- GigE Vision interface with Power over Ethernet option
- Screw mount RJ45 Ethernet connector for secure operation in industrial environments
- Supports cable lengths up to 100 meters (CAT-6 recommended)
- Trigger over Ethernet Action Commands allow for a single cable solution to reduce system costs
- Comprehensive I/O functionality for simplified system integration
- Popular C-Mount lens mount
- Easy camera mounting via standard M3 threads on top and bottom of housing or optional tripod adapter
- Easy software integration with Allied Vision's [Vimba Suite](#) and compatibility to the most popular [third party image-processing libraries](#).

### Hardware options

- Various housing options: Select between standard housing, angled-head, or board level versions

- Various lens mounts: Select between C-Mount, CS-Mount, or M12-Mount (adapter)
- Various optical filters: Select between B 270 ASG protection glass and filter types: Jenofilt 217 IR cut filter, Hoya C-5000 IR cut filter, RG715 IR pass filter, or RG830 IR pass filter.
- Available with Power over Ethernet compliant interface
- Available with white medical design

See the [Modular Concept](#) for lens mount, housing variants, optical filters, case design, and other modular options. See the [Customization and OEM Solutions](#) webpage for additional options.

## Specifications

| <b>Manta</b>                                                                                                                                                                                                                                                                                             | <b>G-1236</b>                                      |
|----------------------------------------------------------------------------------------------------------------------------------------------------------------------------------------------------------------------------------------------------------------------------------------------------------|----------------------------------------------------|
| Interface                                                                                                                                                                                                                                                                                                | IEEE 802.3 1000BASE-T, IEEE 802.3af (PoE) optional |
| Resolution                                                                                                                                                                                                                                                                                               | 4112 (H) × 3008 (V)                                |
| Sensor                                                                                                                                                                                                                                                                                                   | Sony IMX304                                        |
| Sensor type                                                                                                                                                                                                                                                                                              | CMOS                                               |
| Shutter mode                                                                                                                                                                                                                                                                                             | Global shutter                                     |
| Sensor size                                                                                                                                                                                                                                                                                              | Type 1.1                                           |
| Pixel size                                                                                                                                                                                                                                                                                               | 3.45 μm × 3.45 μm                                  |
| Lens mounts (available)                                                                                                                                                                                                                                                                                  | C-Mount, CS-Mount, S-Mount                         |
| Max. frame rate at full resolution                                                                                                                                                                                                                                                                       | 9.7 fps                                            |
| ADC                                                                                                                                                                                                                                                                                                      | 12 Bit                                             |
| Image buffer (RAM)                                                                                                                                                                                                                                                                                       | 128 MByte                                          |
| <b>Imaging performance</b>                                                                                                                                                                                                                                                                               |                                                    |
| Imaging performance data is based on the evaluation methods in the EMVA 1288 Release 3.1 standard for characterization of image sensors and cameras. Measurements are typical values for monochrome models measured at full resolution without optical filter. Contact Sales or AE for more information. |                                                    |
| Quantum efficiency at 529 nm                                                                                                                                                                                                                                                                             | 64 %                                               |
| Temporal dark noise                                                                                                                                                                                                                                                                                      | 2.1 e <sup>-</sup>                                 |
| Saturation capacity                                                                                                                                                                                                                                                                                      | 10400 e <sup>-</sup>                               |
| Dynamic range                                                                                                                                                                                                                                                                                            | 71.8 dB                                            |
| Absolute sensitivity threshold                                                                                                                                                                                                                                                                           | 2.7 e <sup>-</sup>                                 |
| <b>Output</b>                                                                                                                                                                                                                                                                                            |                                                    |
| Bit depth                                                                                                                                                                                                                                                                                                | 8/12 Bit                                           |
| Monochrome pixel formats                                                                                                                                                                                                                                                                                 | Mono8, Mono12Packed, Mono12                        |
| YUV color pixel formats                                                                                                                                                                                                                                                                                  | YUV411Packed, YUV422Packed, YUV444Packed           |
| RGB color pixel formats                                                                                                                                                                                                                                                                                  | RGB8Packed, BGR8Packed                             |
| Raw pixel formats                                                                                                                                                                                                                                                                                        | BayerRG8, BayerRG12, BayerRG12Packed               |
| <b>General purpose inputs/outputs (GPIOs)</b>                                                                                                                                                                                                                                                            |                                                    |
| Opto-isolated I/Os                                                                                                                                                                                                                                                                                       | 2 inputs, 2 outputs                                |

|                                        |                                                                                                       |
|----------------------------------------|-------------------------------------------------------------------------------------------------------|
| <b>Manta</b>                           | <b>G-1236</b>                                                                                         |
| RS232                                  | 1                                                                                                     |
| <b>Operating conditions/dimensions</b> |                                                                                                       |
| Operating temperature                  | +5 °C to +45 °C ambient (without condensation)                                                        |
| Power requirements (DC)                | 8 to 30 VDC AUX or IEEE 802.3af PoE                                                                   |
| Power consumption                      | External power: 3.0 W at 12 VDC   Power over Ethernet: 3.3 W                                          |
| Mass                                   | 190 g; 200 g (PoE)                                                                                    |
| Body dimensions (L × W × H in mm)      | 86.3 × 44 × 29 (including connectors)                                                                 |
| Regulations                            | CE: 2014/30/EU (EMC), 2011/65/EU, including amendment 2015/863/EU (RoHS); FCC Class B; CAN ICES-3 (B) |

## Quantum efficiency

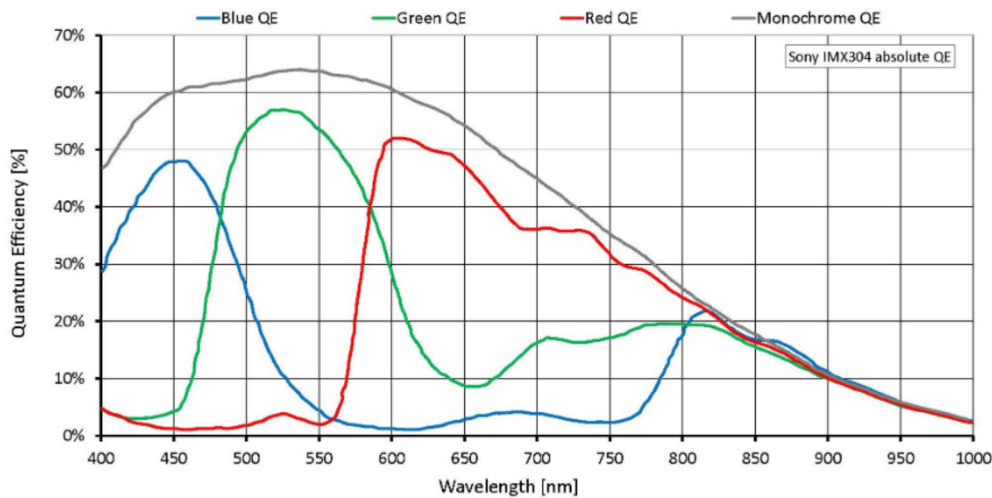

## Features

### Image optimization features:

- Auto gain (manual gain control: 0 to 40 dB; 0.1 dB increments)
- Auto exposure (exposure time control varies by pixel format)
- Auto white balance (G-1236C only)
- Binning
- Black level (offset)



- Color correction, hue, saturation (G-1236C only)
- Decimation
- Gamma correction
- Three look-up tables
- Region of interest, separate region for auto features
- Reverse X/Y

#### Camera control features:

- Auto-iris (video type)
- Event channel
- Image chunk data
- IEEE 1588 Precision Time Protocol
- Storable user sets
- StreamBytesPerSecond (bandwidth control)
- Stream hold
- Sync out modes: Trigger ready, input, exposing, readout, imaging, strobe, GPO
- Temperature monitoring (main board)
- Trigger over Ethernet Action Commands

Technical drawing

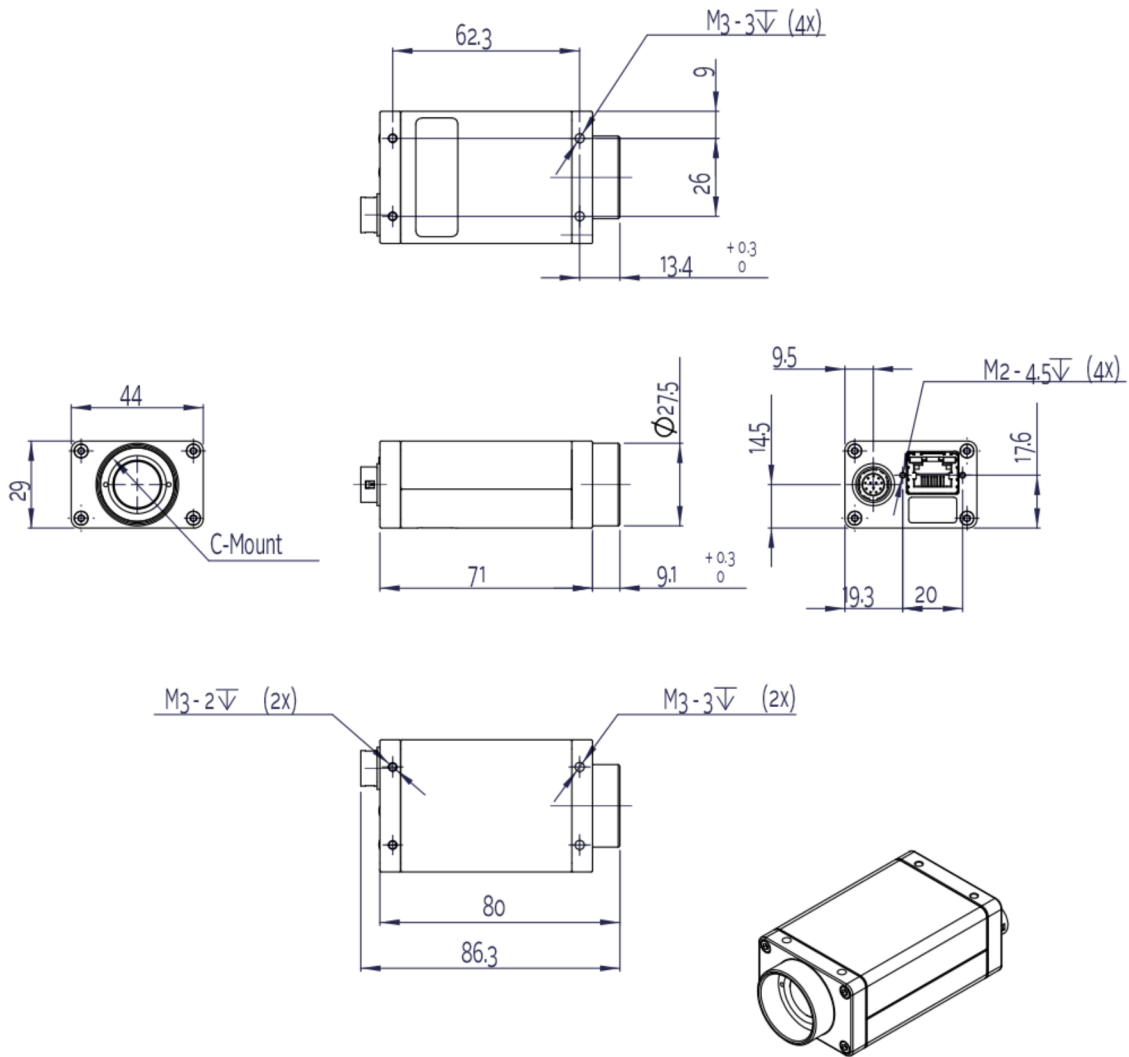



## Applications

Manta G-1236 is ideal for a wide range of applications including:

- Machine Vision
- Broadcast analysis requiring Full HD such as sports analytics
- Industrial inspection
- Security and surveillance
- Intelligent traffic solutions (ITS), traffic (traffic monitoring, speed enforcement, toll collection)
- Low light or high sensitivity conditions
- Outdoor applications with dynamic lighting situations