

Manta

G-158



- Sony IMX273 CMOS sensor
- Power over Ethernet option
- Angled-head and board level variants
- Video-iris lens control

GigE Vision camera featuring the Sony IMX273 CMOS sensor

Manta G-158 is a 1.58 megapixel machine vision camera with a GigE compliant Gigabit Ethernet port and Hirose I/O port. Manta G-158 incorporates the high quality Type 1/2.9 (6.3 mm diagonal) Sony IMX273 CMOS sensor with Pregius global shutter technology. The Sony IMX273 CMOS sensor provides high frame rates with excellent picture quality. The Manta G-158 is offered in monochrome and color models. At full resolution, this camera achieves 75.2 frames per second. With a smaller region of interest, higher frame rates are possible. The Manta G-158 is an ideal replacement for legacy CCD models.

Manta is one of Allied Vision's versatile GigE Vision cameras with a wide range of features. Particular highlights are the three look-up tables, sophisticated color correction capabilities, a robust metal housing, and many modular options. By default monochrome models ship with B 270 ASG protection glass and color models ship with a Type Hoya C-5000 IR cut filter.

Benefits and features

- Monochrome (G-158B) and color (G-158C) models
- GigE Vision interface with Power over Ethernet option
- Screw mount RJ45 Ethernet connector for secure operation in industrial environments
- Supports cable lengths up to 100 meters (CAT-6 recommended)
- Trigger over Ethernet Action Commands allow for a single cable solution to reduce system costs
- Comprehensive I/O functionality for simplified system integration
- Popular C-Mount lens mount
- Easy camera mounting via standard M3 threads on top and bottom of housing or optional tripod adapter
- Easy software integration with Allied Vision's [Vimba Suite](#) and compatibility to the most popular [third party image-processing libraries](#).

Hardware options

- Various housing options: Select between standard housing, angled-head, or board level versions
- Various lens mounts: Select between C-Mount, CS-Mount, or M12-Mount (adapter)
- Various optical filters: Select between B 270 ASG protection glass and filter types: Jenofilt 217 IR cut filter, Hoya C-5000 IR cut filter, RG715 IR pass filter, or RG830 IR pass filter.
- Available with Power over Ethernet compliant interface
- Available with white medical design

See the [Modular Concept](#) for lens mount, housing variants, optical filters, case design, and other modular options. See the [Customization and OEM Solutions](#) webpage for additional options.

Specifications

Manta	G-158
Interface	IEEE 802.3 1000BASE-T, IEEE 802.3af (PoE) optional
Resolution	1456 (H) × 1088 (V)
Sensor	Sony IMX273
Sensor type	CMOS
Shutter mode	Global shutter
Sensor size	Type 1/2.9
Pixel size	3.45 μm × 3.45 μm
Lens mounts (available)	C-Mount, CS-Mount, S-Mount
Max. frame rate at full resolution	75.2 fps
ADC	12 Bit
Image buffer (RAM)	128 MByte

Imaging performance

Imaging performance data is based on the evaluation methods in the EMVA 1288 Release 3.1 standard for characterization of image sensors and cameras. Measurements are typical values for monochrome models measured at full resolution without optical filter. Contact Sales or AE for more information.

Quantum efficiency at 529 nm	64 %
Temporal dark noise	2.14 e ⁻
Saturation capacity	10500 e ⁻
Dynamic range	71.6 dB
Absolute sensitivity threshold	2.8 e ⁻

Output

Bit depth	8/12 Bit
Monochrome pixel formats	Mono8, Mono12Packed, Mono12
YUV color pixel formats	YUV411Packed, YUV422Packed, YUV444Packed
RGB color pixel formats	RGB8Packed, BGR8Packed

Manta	G-158
Raw pixel formats	BayerRG8, BayerRG12, BayerRG12Packed
General purpose inputs/outputs (GPIOs)	
Opto-isolated I/Os	2 inputs, 2 outputs
RS232	1
Operating conditions/dimensions	
Operating temperature	+5 °C to +45 °C ambient (without condensation)
Power requirements (DC)	8 to 30 VDC AUX or IEEE 802.3af PoE
Power consumption	External power: 2.79 W at 12 VDC Power over Ethernet: 3.26 W
Mass	190 g; 200 g (PoE)
Body dimensions (L × W × H in mm)	86.3 × 44 × 29 (including connectors)
Regulations	CE: 2014/30/EU (EMC), 2011/65/EU, including amendment 2015/863/EU (RoHS); FCC Class B; CAN ICES-3 (B)

Quantum efficiency

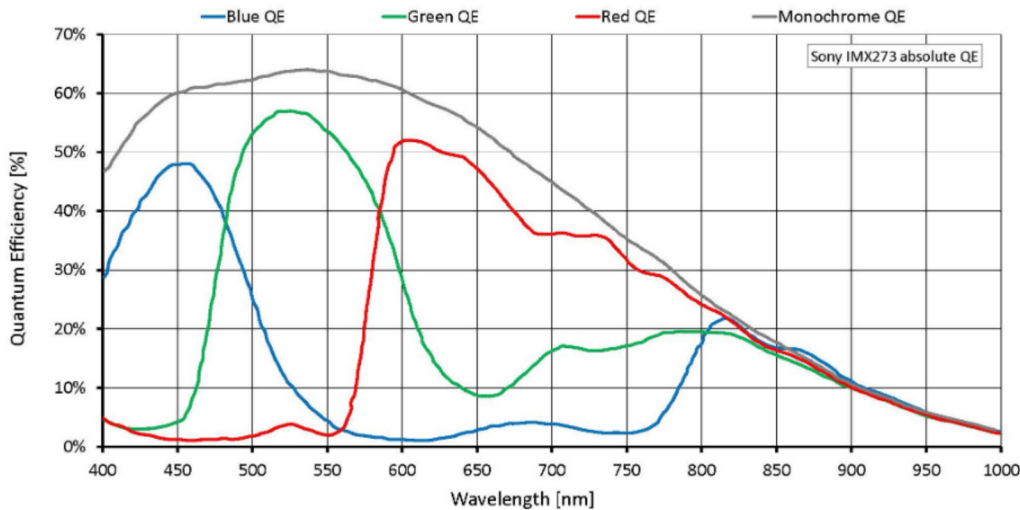

Features

Image optimization features:

- Auto gain (manual gain control: 0 to 40 dB; 0.1 dB increments)
- Auto exposure (exposure time control varies by pixel format)



- Auto white balance (G-158C only)
- Binning
- Black level (offset)
- Color correction, hue, saturation (G-158C only)
- Decimation
- Gamma correction
- Three look-up tables
- Region of interest, separate region for auto features
- Reverse X/Y

Camera control features:

- Auto-iris (video type)
- Event channel
- Image chunk data
- IEEE 1588 Precision Time Protocol
- Storable user sets
- StreamBytesPerSecond (bandwidth control)
- Stream hold
- Sync out modes: Trigger ready, input, exposing, readout, imaging, strobe, GPO
- Temperature monitoring (main board)
- Trigger over Ethernet Action Commands

Technical drawing

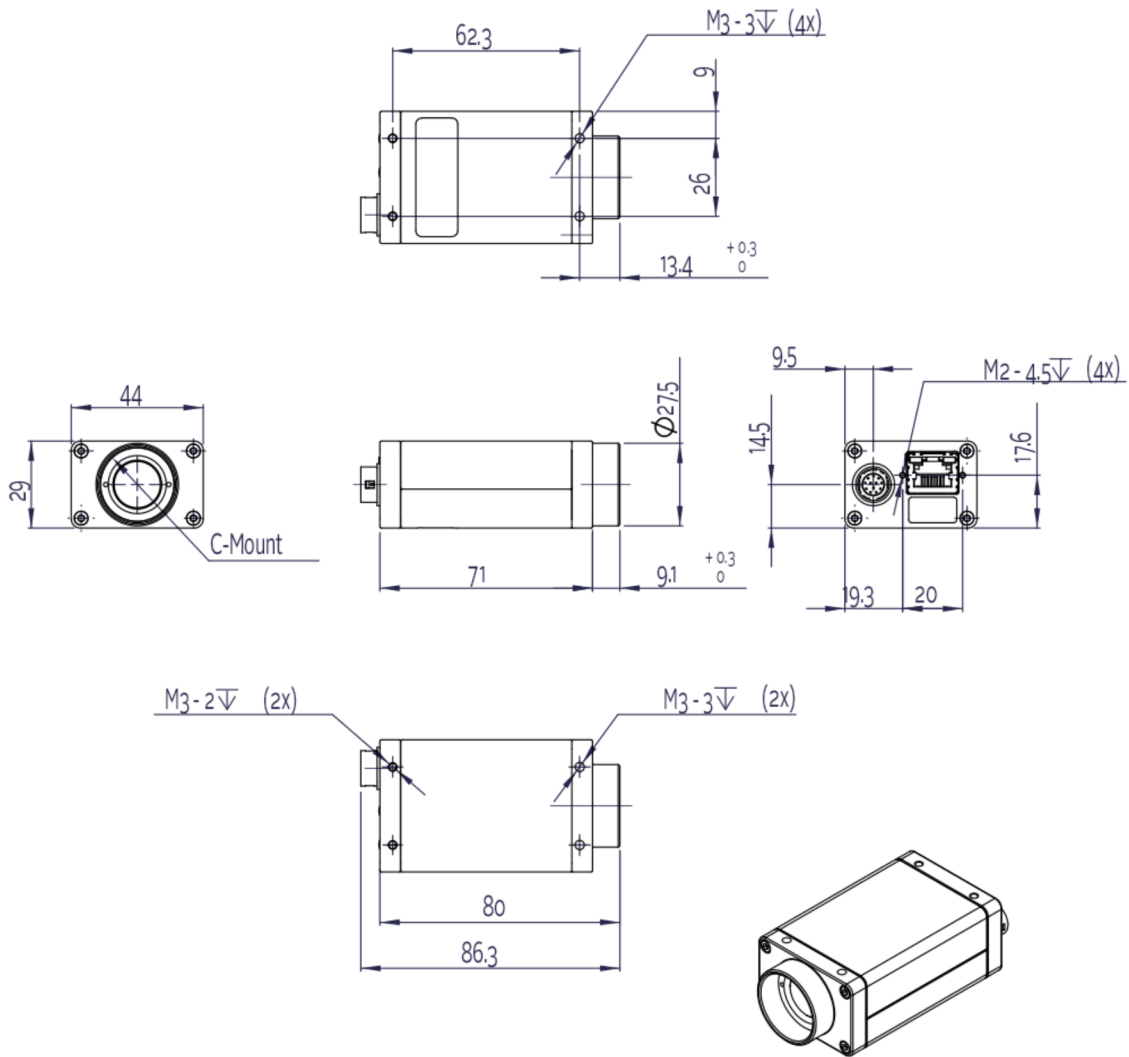



Applications

The Manta G-158 is the perfect model for industrial applications that require accurate imaging of fast-moving subjects. Equipped with a Pregius global shutter function, the camera provides high-quality image capture that is not affected by focal plane distortion or flash bands.

Manta G-158 is ideal for a wide range of applications including:

- Machine Vision
- Industrial inspection
- Security and surveillance
- Intelligent traffic solutions (ITS) including traffic monitoring, speed enforcement, and toll collection
- Low light or high sensitivity conditions
- Outdoor applications with dynamic lighting situations