

# Manta

## G-505



- Versatile 5 megapixel camera
- 15 fps at full resolution
- Power over Ethernet option
- Video-iris lens control

## GigE Vision camera with the 5 megapixel Sony ICX625 CCD sensor

Manta G-505 is a 5.0 Megapixel machine vision camera with a GigE compliant Gigabit Ethernet port and Hirose I/O port. Manta G-505 incorporates the high quality Type 2/3 (11.016 mm diagonal) Sony ICX625 CCD sensor with Super HAD CCD technology and global shutter. At full resolution, this camera runs 15.0 frames per second. With a smaller region of interest, higher frame rates are possible.

Manta is one of Allied Vision's versatile GigE Vision cameras with a wide range of features. Particular highlights are the three look-up tables, sophisticated color correction capabilities, a robust metal housing, and many modular options. By default monochrome models ship with B 270 ASG protection glass and color models ship with a Type Hoya C-5000 IR cut filter.

### Benefits and features

- Monochrome (G-505B) and color (G-505C) models
- GigE Vision interface with Power over Ethernet option
- Screw mount RJ45 Ethernet connector for secure operation in industrial environments
- Supports cable lengths up to 100 meters (CAT-6 recommended)
- Trigger over Ethernet Action Commands allow for a single cable solution to reduce system costs
- Comprehensive I/O functionality for simplified system integration
- Popular C-Mount lens mount
- Easy camera mounting via standard M3 threads on top and bottom of housing or optional tripod adapter
- Easy software integration with Allied Vision's [Vimba SDK](#) and compatibility to the most popular [third party image-processing libraries](#).

## Hardware options

- Various lens mounts: Select between C-Mount, CS-Mount, or M12-Mount (adapter)
- Various optical filters: Select between B 270 ASG protection glass and filter types: Jenofilt 217 IR cut filter, Hoya C-5000 IR cut filter, RG715 IR pass filter, or RG830 IR pass filter.
- Available with Power over Ethernet compliant interface
- Available with white medical design

See the [Modular Concept](#) for lens mount, optical filters, case design, and other modular options. See the [Customization and OEM Solutions](#) webpage for additional options.

## Specifications

Manta	G-505
Interface	IEEE 802.3 1000BASE-T, IEEE 802.3af (PoE) optional
Resolution	2452 (H) × 2056 (V)
Sensor	Sony ICX625
Sensor type	CCD Progressive
Shutter mode	Global shutter
Sensor size	Type 2/3
Pixel size	3.45 μm × 3.45 μm
Lens mounts (available)	C-Mount, CS-Mount, S-Mount
Max. frame rate at full resolution	15 fps
ADC	14 Bit
Image buffer (RAM)	128 MByte

### Imaging performance

Imaging performance data is based on the evaluation methods in the EMVA 1288 Release 3.1 standard for characterization of image sensors and cameras. Measurements are typical values for monochrome models measured at full resolution without optical filter. Contact Sales or AE for more information.

Quantum efficiency at 529 nm	57 %
Temporal dark noise	8.8 e <sup>-</sup>
Saturation capacity	7500 e <sup>-</sup>
Dynamic range	58.1 dB
Absolute sensitivity threshold	9.3 e <sup>-</sup>

### Output

Bit depth	8/12 Bit
Monochrome pixel formats	Mono8, Mono12Packed, Mono12
YUV color pixel formats	YUV411Packed, YUV422Packed, YUV444Packed
RGB color pixel formats	RGB8Packed, BGR8Packed
Raw pixel formats	BayerRG8, BayerRG12, BayerRG12Packed

Manta	G-505
	<b>General purpose inputs/outputs (GPIOs)</b>
Opto-isolated I/Os	2 inputs, 2 outputs
RS232	1
	<b>Operating conditions/dimensions</b>
Operating temperature	+5 °C to +45 °C ambient (without condensation)
Power requirements (DC)	8 to 30 VDC AUX or IEEE 802.3af PoE
Power consumption	External power: 3.9 W at 12 VDC   Power over Ethernet: 4.5 W
Mass	190 g; 200 g (PoE)
Body dimensions (L × W × H in mm)	86.3 × 44 × 29 (including connectors)
Regulations	CE: 2014/30/EU (EMC), 2011/65/EU, including amendment 2015/863/EU (RoHS); FCC Class B; CAN ICES-3 (B)

## Quantum efficiency

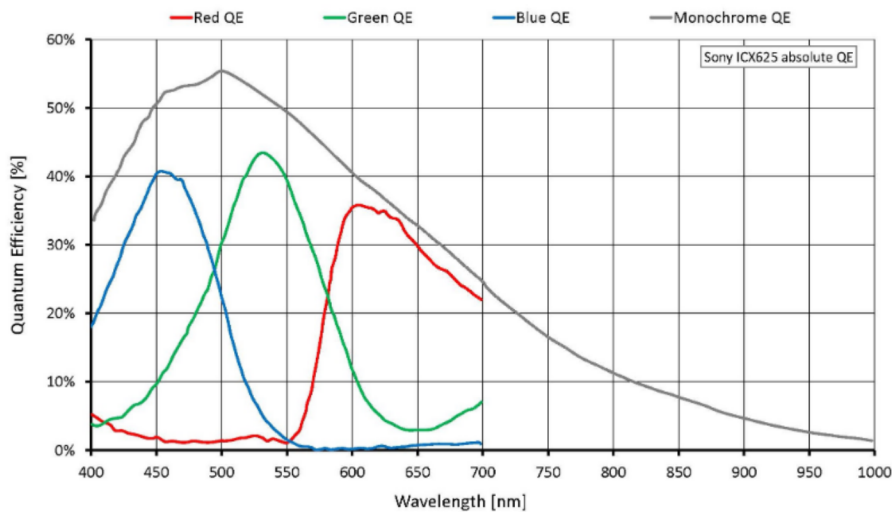

## Features

### Image optimization features:

- Auto gain (manual gain control: 0 to 31 dB; 1 dB increments)
- Auto exposure (49  $\mu$ s to 38 s; 1  $\mu$ s increments)
- Auto white balance (G-505C only)



- Binning
- Black level (offset)
- Color correction, hue, saturation (G-505C only)
- Decimation
- Gamma correction
- Three look-up tables
- Region of interest, separate region for auto features
- Reverse X

#### Camera control features:

- Auto-iris (video type)
- Event channel
- Image chunk data
- IEEE 1588 Precision Time Protocol
- Storable user sets
- StreamBytesPerSecond (easy bandwidth control)
- Stream hold
- Sync out modes: Trigger ready, input, exposing, readout, imaging, strobe, GPO
- Temperature monitoring (main board)
- Trigger over Ethernet Action Commands

## Technical drawing

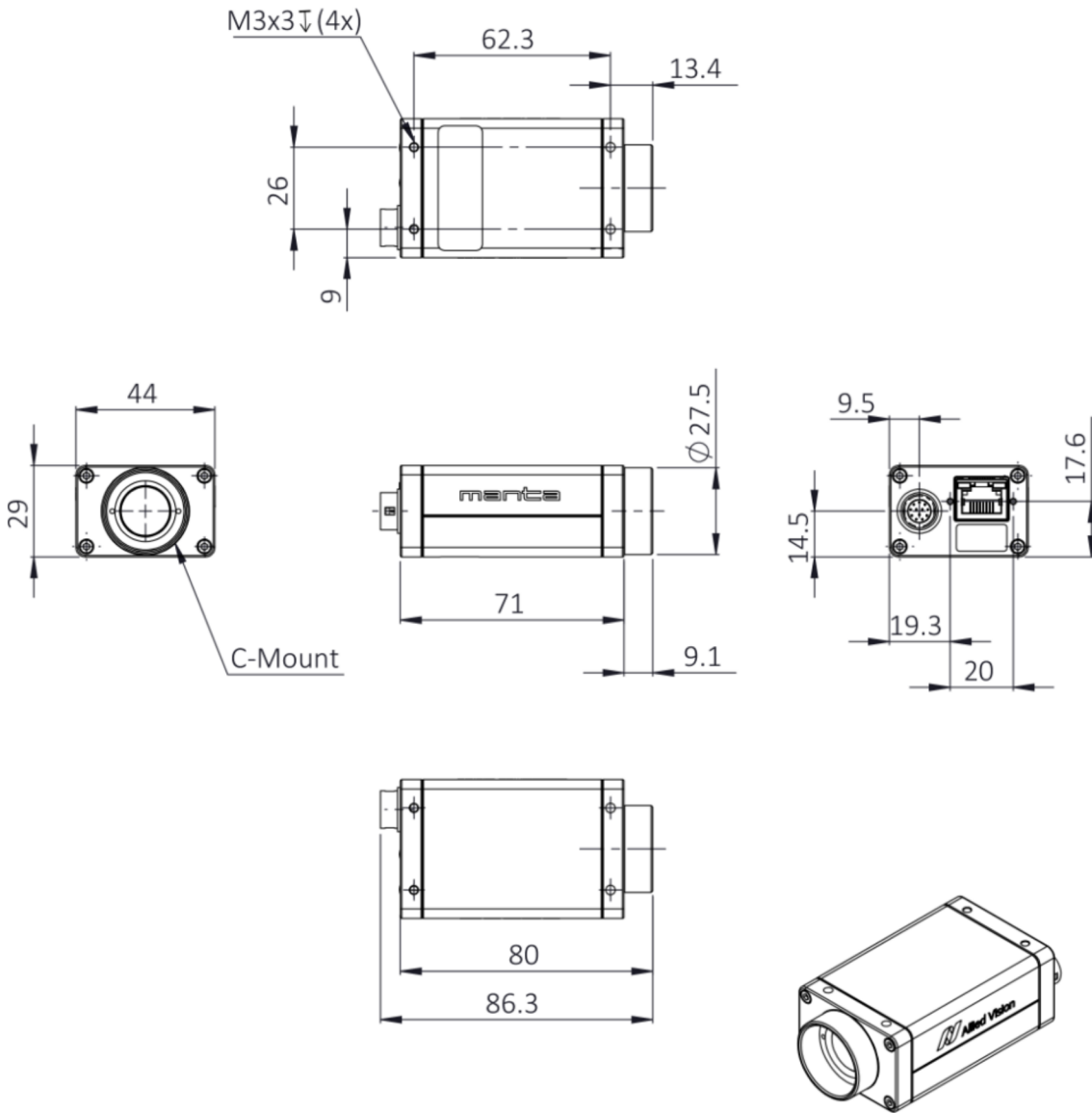



## Applications

Manta G-505 is ideal for a wide range of applications including:

- Machine vision
- Inspection and quality control
- Microscopy
- Intelligent traffic solutions (ITS)
- Automation
- Logistics