

Prosilica GT

5400



- High spatial resolution
- IEEE 1588 PTP
- Power over Ethernet
- Defect pixel masking

16.8 megapixel machine vision camera with Sony IMX387 CMOS sensor

Prosilica GT5400 is a large format camera equipped with a GigE Vision compliant Gigabit Ethernet port and Hirose I/O port. This camera incorporates the second generation Sony IMX387 CMOS sensor with Pregius global shutter technology. This sensor offers high quantum efficiency, high dynamic range and spatial resolution, low readout noise and provides excellent imaging performance. At full resolution, this camera runs at 7.14 frames per second. With a smaller region of interest, higher frame rates are possible. This camera is ideal for high-definition imaging applications with demanding requirements on robustness and design-in flexibility. The rugged camera design, effective passive cooling, and comprehensive feature set make these Prosilica GT5400 cameras an ideal choice for a wide range of applications. Prosilica GT5400 has F-Mount as standard. A new C-Mount option is available via our Modular Concept.

By default, monochrome models ship with no optical filter and color models ship with a Type IRC30 IR cut filter.

Benefits and features

- Monochrome (GT5400) and color (GT5400C) models
- Screw mount RJ45 Ethernet connector for secure operation in industrial environments
- Supports cable lengths up to 100 meters (CAT-6 recommended)
- Trigger over Ethernet Action Commands allow for a single cable solution to reduce system costs
- Comprehensive I/O functionality for simplified system integration
- Planarity adjusted (PA) EF Lens Mount (option -18) for electronic control of aperture and autofocus
- Easy camera mounting via standard M3 threads at all sides and 1/4-20 tripod mounting hole
- Defect pixel masking feature with the Defect Mask Loader tool that allows you to manage a user defined defective pixel list to match your application and optimize the life cycle of the camera.

- Easy software integration with Allied Vision's [Vimba Suite](#) and compatibility to the most popular [third party image-processing libraries](#).

Hardware options

- Various lens mounts: Select between F-Mount, F-Mount PA, EF-Mount PA, M42-Mount, M42-Mount PA, M58-Mount, M58-Mount PA, TFL-Mount, or C-Mount
- Various optical filters: Select between B 270 ASG protection glass and filter types: IRC30 IR cut filter, Schneider 486 IR cut filter

See the [Modular Concept](#) for lens mount and optical filters options. See the [Customization and OEM Solutions](#) webpage for additional options.

Specifications

Prosilica GT	5400
Interface	IEEE 802.3 1000BASE-T, IEEE 802.3af (PoE)
Resolution	5472 (H) × 3084 (V)
Sensor	Sony IMX387
Sensor type	CMOS
Shutter mode	Global shutter
Sensor size	Type 4/3
Pixel size	3.45 μm × 3.45 μm
Lens mounts (available)	F-Mount, F-Mount PA, EF-Mount PA, M42-Mount, M42-Mount PA, M58-Mount, M58-Mount PA, C-Mount, TFL-Mount
Max. frame rate at full resolution	7.14 fps
ADC	12 Bit
Image buffer (RAM)	128 MByte
Imaging performance	
Imaging performance data is based on the evaluation methods in the EMVA 1288 Release 3.1 standard for characterization of image sensors and cameras. Measurements are typical values for monochrome models measured at full resolution without optical filter.	
Quantum efficiency at 529 nm	64 %
Temporal dark noise	2.3 e ⁻
Saturation capacity	10300 e ⁻
Dynamic range	72 dB
Absolute sensitivity threshold	2.7 e ⁻
Output	
Bit depth	12 Bit
Monochrome pixel formats	Mono8, Mono12Packed, Mono12

Prosilica GT	5400
YUV color pixel formats	YUV411Packed, YUV422Packed, YUV444Packed
RGB color pixel formats	RGB8Packed, BGR8Packed
Raw pixel formats	BayerRG8, BayerRG12, BayerRG12Packed
General purpose inputs/outputs (GPIOs)	
TTL I/Os	1 input, 2 outputs
Opto-isolated I/Os	1 input, 2 outputs
RS232	1
Operating conditions/dimensions	
Operating temperature	-20 °C to +50 °C housing (without condensation)
Power requirements (DC)	7 to 25 VDC AUX or IEEE 802.3at Type 1 PoE
Power consumption	External power: 5.2 W at 12 VDC Power over Ethernet: 6.4 W
Mass	372 g
Body dimensions (L × W × H in mm)	96 × 66 × 53.3 (including connectors)
Regulations	CE: 2014/30/EU (EMC), 2011/65/EU, including amendment 2015/863/EU (RoHS); FCC Class A; CAN ICES-3 (A)

Quantum efficiency

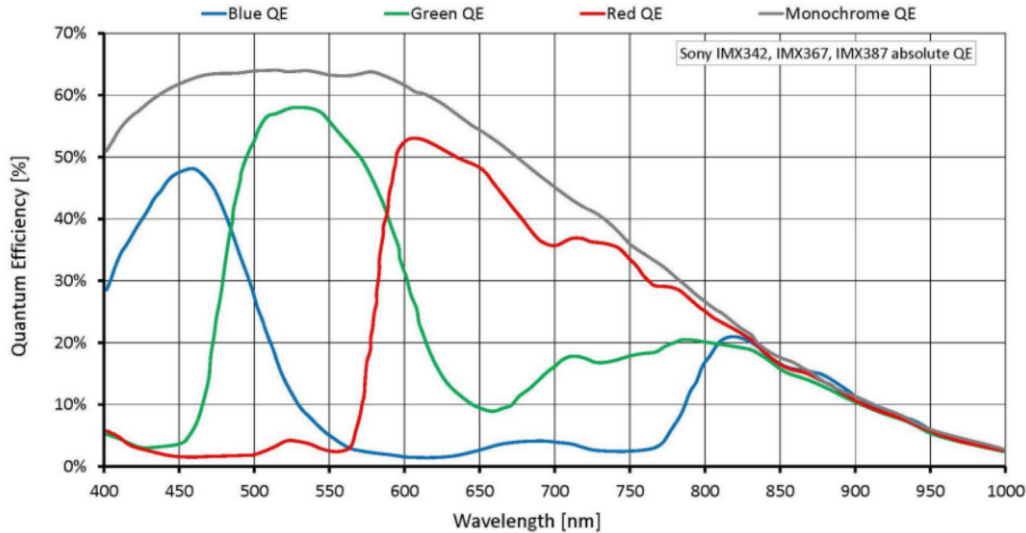



Features

Image optimization features:

- Auto gain (manual gain control: 0 to 40 dB; 0.1 dB increments)
- Auto exposure (exposure time control varies by per pixel format)
- Auto white balance (GT5400C only)
 - White balance ratio from 0.01 to 3.99
- Binning (horizontal and vertical)
- BlackLevel (offset)
- Color correction, hue, saturation (GT5400C only)
- Decimation X/Y
- Defect pixel masking (user defined with Defect Mask Loader tool)
 - Mask up to 512 pixels
- Gamma correction
- One look-up table
- Region of interest, separate region for auto features
- Reverse X/Y

Camera control features:

- Automatic EF lens control (option -18)
- Event channel
- Image chunk data
- IEEE 1588 Precision Time Protocol
- RS232
- Storable user sets
- StreamBytesPerSecond (bandwidth control)
- Stream hold
- Sync out modes: Trigger ready, input, exposing, readout, imaging, strobe, GPO
- Temperature monitoring (sensor board and main board)
- Trigger over Ethernet via Action Commands

Technical drawing

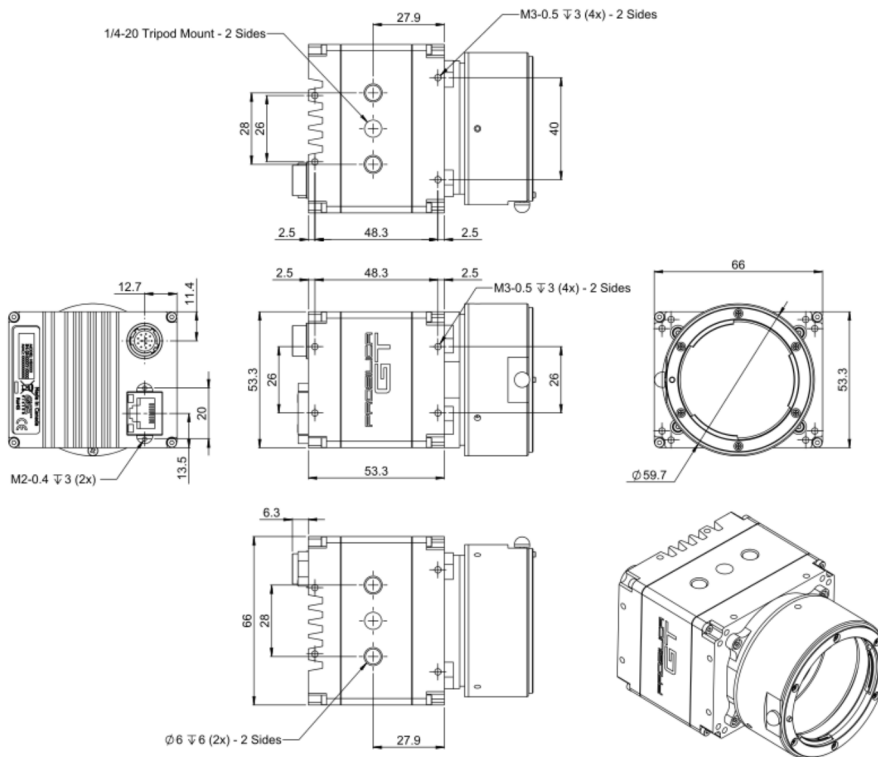



Applications

Prosilica GT5400 is ideal for a wide range of applications including:

- Industrial inspection including display inspection, surface inspection, semiconductor packaging inspection, print inspection, 2D/3D metrology, laser beam profiling, and automated optical inspection
- Outdoor imaging applications including railway inspection, aerial imaging, traffic and transportation, surveillance, and defense
- Medical and life sciences applications including lab and biomedical imaging, pharma and cosmetic inspection, track and trace applications
- Archival imaging of documents and digitization of film